

MAXPULL WINCH



STEEL HAND WINCHES

Model : GM, MR, MC

STAINLESS STEEL HAND WINCHES

Model : ST, SB, ESB, RST, RSB, ERSB, STC, SBC, ESBC

Instruction Manual

 **WARNING**

- For your safety, always read this manual and understand the contents fully before starting operation.
- Keep this manual at a designated place at all times to have quick access when required.

Serial number :

Date of manufacture :

MAXPULL MACHINERY & ENGINEERING CO., LTD.

INTRODUCTION

This winch is composed of several units that contain rotating and driving sections. If instruction in this manual are ignored or the winch is wrongly handled or operated, it can result in serious injuries or damage to the winch and other properties.

To avoid accidents and troubles, make sure to carefully read this manual and understand their contents thoroughly before starting operation.

This manual covers the matters must not be done or cannot be done as much as possible. However, it is impossible to cover all the potential hazards for various applications. Therefore, matters not described as “possible” in the manual should be regarded as “impossible”.

If any question or doubt arises concerning the contents of this manual, contact our company first. Never operate the winch until the problem is solved.

■ Contact Information

For more information, contact the following :

1296-22, Nakaya, Nishifukai, Nagareyama-shi Chiba 270-0107 JAPAN

MAXPULL MACHINERY&ENGINEERING CO., LTD.

TEL : +81-4-7186-6797

FAX : +81-4-7186-6798

E-mail : maxpull@maxpull.co.jp

Web Site : <http://www.maxpull.co.jp>

**Reproduction or copying of this manual
without prior consent of
MAXPULL MACHINERY&ENGINEERING CO., LTD.
is strictly prohibited.**

■ **Change or Modification of the Winch**

After delivery of the winch to the user's site, do not modify or change any part of the winch without prior consent of MAXPULL.

MAXPULL is not in a position in any event to bear any responsibility whatsoever for potential troubles of any kind to be incurred through any modification made by the customer with no prior consent of MAXPULL.

■ **Change of Specifications**

Details of all specifications and technical contents in this manual are subject to change without prior notice for improvement and development. As a result, illustrations and description of this manual may slightly differ from the actual winch.

■ **Resale or Leasing of the Winch**

At the time of resale, leasing or lending out the winch to any third party, make sure to include all manuals and other documents supplied with the winch.

■ **Indemnity**

MAXPULL shall be discharged from any obligations arising from personal injuries or property damages resulting from different interpretations of the descriptions of this manual.



■ **Safety Alert Symbols and Warning Signs**

Safety Alert Symbols

There are the industry “Safety Alert Symbols”. These symbols are used to call your attention to item or operation that could be dangerous to you or other personnel using this winch.

Read these messages and follow the instructions carefully.

It is essential that you read the instructions and safety regulations before you attempt to use the winch.

Indication	Definition
 DANGER	Indicates an imminently hazardous situation which, if ignored, will result in death or serious injury and/or property damage.
 WARNING	Indicates a potentially hazardous situation which, if ignored, could result in death or serious injury and/or property damage.
 CAUTION	Indicates a potentially hazardous situation which, if ignored, could result in minor or moderate injury and/or property damage.

■ **In addition to the Safety Alert Symbols, the marks below will also appear in this manual. Read the following explanation in order to handle the winch correctly.**



Indication	Definition
 Important !	Indicates referential information or points to which special attention should be paid during operation. If ignored, the winch could be damaged.
 Note	Indicates referential information or points which are helpful during operation.
 Refer	Indicates referential page or clause.

Table of Contents

Chapter 1 SAFETY PRECAUTIONS

1.1	Basic Safety Precautions	1-1
1.2	Hazardous Area	1-4
1.2.1	Rotating Area	1-4
1.3	Safety Devices	1-5
1.3.1	Location and Functions of Safety Devices	1-5
1.4	Name Plate and Warning Labels	1-6
1.4.1	Location of Name Plate	1-6
1.4.2	Types and Location of Warning Labels	1-6

Chapter 2 OUTLINE

2.1	Outline of Hand Winch	2-1
2.2	Winch Overview	2-1
2.3	Specifications	2-2
2.3.1	Specifications on Model GM and MR	2-2
2.3.2	Specifications on Model MC	2-3
2.3.3	Specifications on Model ST, SB, ESB, RST, RSB and ERSB	2-4
2.3.4	Specifications on Model STC, SBC and ESBC	2-5
2.4	Names of Each Part	2-7
2.4.1	Names of Each Part for Model GM, ST, SB and ESB	2-7
2.4.2	Names of Each Part for Model MC, STC, SBC and ESBC	2-7
2.4.3	Names of Each Part for Model MR, RST, RSB and ERSB	2-8
2.4.4	Special Types	2-8

Chapter 3 INSTALLATION

3.1	Installation Outline	3-1
3.2	Unpacking	3-1
3.3	Inspection of Components and Attachments	3-1
3.4	Selection of Setting Site	3-1
3.5	Installation of the Winch	3-2
3.6	Installation of the Pulley	3-4
3.7	Anchoring of the Wire Rope	3-5
3.7.1	Anchoring the Wire Rope for Model GM-1 to GM-10, MR-1 to MR-10, ST-1 to ST-10, SB-1 to SB-10, ESB-1 to ESB-10, RST-1 to RST-10, RSB-1 to RST-10 and ERSB-1 to ERSB-10	3-6
3.7.2	Anchoring the Wire Rope for Model GM-20 and MR-20	3-7
3.7.3	Anchoring the Wire Rope for Model GM-30 and MR-30	3-8

Chapter 4 OPERATION

4.1	Inspection before Operation	4-1
4.1.1	Checking the Stopper Arm Position	4-1
4.1.2	Checking the Brake Operation	4-2
4.1.3	Checking the Wire Rope Winding Direction	4-2
4.2	Fastening of Handle	4-3
4.3	Handle Operation	4-3
4.3.1	Ratchet Handle Operation for Model MR, RST, RSB and ERSB	4-4
4.3.2	Handle Operation for Model GM-20 and MC-20	4-5
4.3.3	Handle Operation with the Load Lifted up (Exclude Model MR, RST, RSB and ERSB) ..	4-6
4.3.4	Winding Direction	4-7

Chapter 5 INSPECTION / SERVICE / MAINTENANCE

5.1	Inspection / Service	5-1
5.1.1	Daily Inspection	5-1
5.1.2	Periodical Inspection	5-2
5.2	Maintenance	5-8
5.2.1	Troubleshooting and its measures	5-8

APPENDIX

Appendix 1.	MAXPULL Winch Inspection Sheet	App-1
Appendix 2.	Parts List for Each Model	App-2

Chapter 1 SAFETY PRECAUTIONS

1.1	Basic Safety Precautions	1-1
1.2	Hazardous Area	1-4
1.2.1	Rotating Area	1-4
1.3	Safety Devices	1-5
1.3.1	Location and Functions of Safety Devices	1-5
1.4	Name Plate and Warning Labels	1-6
1.4.1	Location of Name Plate	1-6
1.4.2	Types and Location of Warning Labels	1-6

1.1 Basic Safety Precautions



Carefully read this manual to understand the contents before starting operation. Ignoring this instruction could result in serious injury.

- Do not operate or touch without reading the manual. Always operate the winch following instructions in the manual. Avoid doing anything not mentioned in the manual.
- Understand potentially hazardous sections of the machine and how they could be hazardous.
Understand how to avoid these hazards and then how to treat an injured person in case of emergency.
- Before use, be sure to check and comply with the laws, regulations and standards related to the product in the area where you use the winch.
- Never operate the winch based on your own judgement or assumption.
- If instructions in the manual are not clear or how to operate is unknown, immediately contact the supervisor or your local distributor for any doubts.



Refer to "INTRODUCTION".



CALIFORNIA PROPOSITION 65 WARNING:

This product can expose you to chemicals including lead and cadmium or carbon black, which are known to the State of California to cause cancer, and birth defects or other reproductive harm. For more information go to www.P65Warnings.ca.gov.

 DANGER

- **Only qualified personnel can operate the installation of the winch.**
- **Only qualified personnel trained for the winch's correct operation with sufficient knowledge for the safety as well as being authorized by the supervisor can operate the winch.**
- **Keep children, pregnant women, and all other unnecessary people away from the winch and working area.**

- Only qualified personnel can do the installation work.
- Only qualified personnel authorize by the supervisor can operate the winch. Anybody unqualified, unskilled for the winch operation or lacking in knowledge for safe operation should not operate the winch.
- Only qualified personnel authorize by the supervisor can do the maintenance and inspection.

 WARNING

Keep the instruction manual at a designated place for quick access whenever required.

- Choose a personnel to be in charge of keeping the instruction manual at a designated place, not to be stained or lost.
- If the manual is lost or damaged, contact MAXPULL MACHINERY & ENGINEERING Co., Ltd. or your local distributor. Let us know the winch model and its serial number in such a case to supply a new instruction manual at your own cost.



Always wear clothes suitable for installing and operating the winch.

- Bundle long hair neatly and cover it with a work cap to avoid getting entangled in the winch.
- Always wear anti-slip safety shoes to protect your toes and keep proper footing and balance at all times.
- Always wear safety glasses, helmet, heavy duty working gloves, and protective clothing when handling wire ropes and winches.
- Never wear such clothes with loose bottoms or sleeves to avoid getting caught in the winch.
- Never wear such accessories as a ring, bracelet, necklace or wrist watch to avoid getting caught in the winch.
- Never operate the winch just after drinking alcohol or having medicine for your sickness.
- Never operate the winch when you are tired.

1.2 Hazardous Area

1.2.1 Rotating Area

WARNING

- The winch contains a drum and it winds the wire rope.
Never touch the winch while the drum winds wire rope. Otherwise, your hand(s) could be caught.
- When maintaining and inspecting the winch, make sure that there is no load.

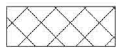

Hazardous Area

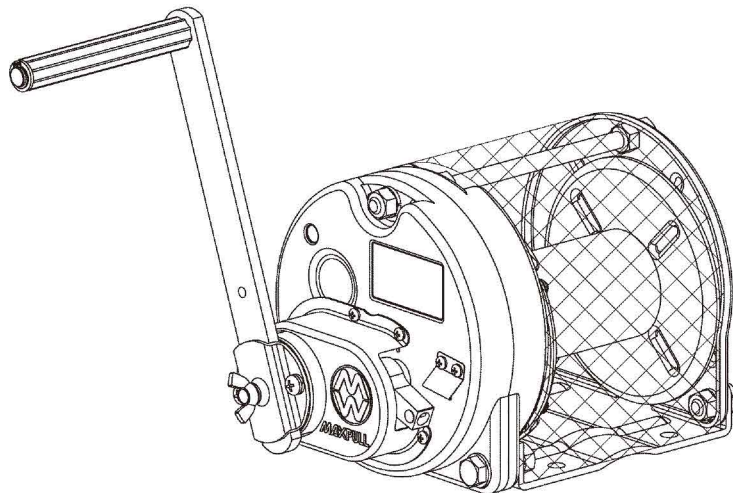

1.3 Safety Devices

This winch is equipped with safety devices. The safety devices, however, have only specific functions and cannot always protect operators from being exposed to hazardous situations. Therefore, understand limited functions, contents and locations of the safety devices fully to operate them .(Exclude TYPE SI, SIC and NSIL)

● List of Safety Devices

No.	Name	Location
①	Safety Leaf Spring	Near the Stopper Arm

1.3.1 Location and Functions of Safety Devices

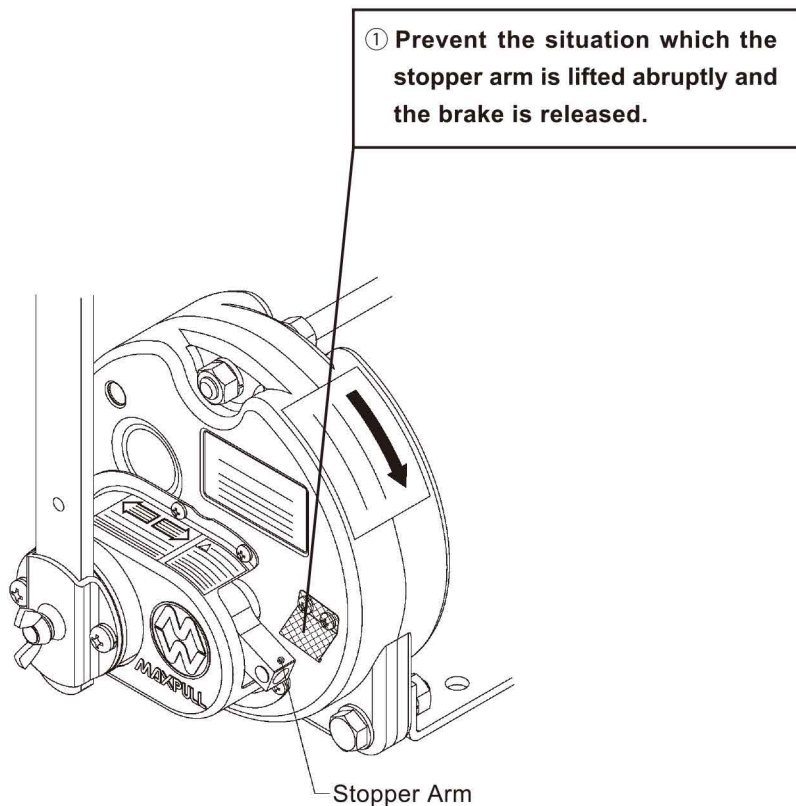

1.4 Name Plate and Warning Labels

The following labels and name plate are attached to the winch. Read and understand the contents of each label fully before starting operation. If any label or name plate becomes damaged or illegible, contact MAXPULL MACHINERY & ENGINEERING CO., Ltd. or your local distributor immediately. A replacement will be supplied at your own cost.

WARNING

- Check the measurement unit of pound(lbs) or kilogram(kgf) on name plate and make sure that the load must not exceed the load rating of the winch before use the winch.
- Never remove nor disfigure any warning label or name plate on the winch.

1.4.1 Location of Name Plate

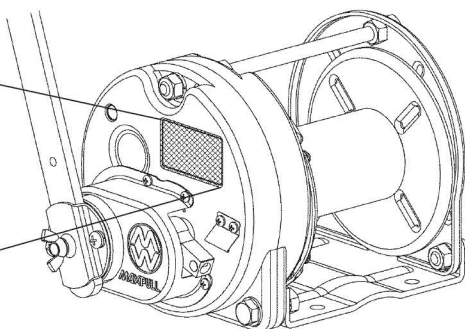

• There are two types of Name Plate which indicated at Metric System and Yard-Pound System.

1.4.2 Types and Location of Warning Labels

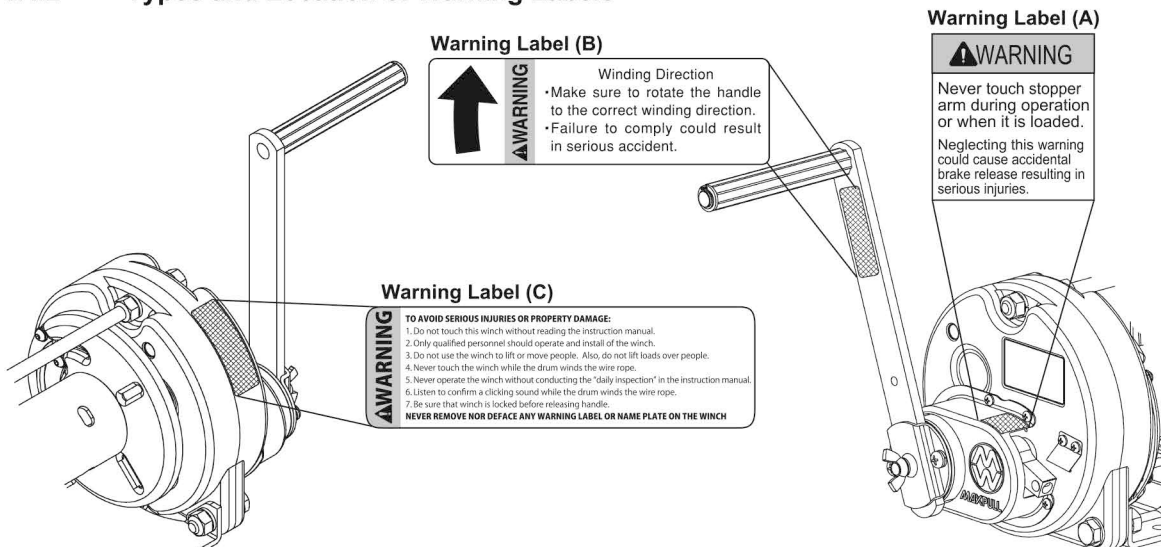

Chapter 2 OUTLINE

2.1	Outline of Hand Winch	2-1
2.2	Winch Overview	2-1
2.3	Specifications	2-2
2.3.1	Specifications on Model GM and MR	2-2
2.3.2	Specifications on Model MC	2-3
2.3.3	Specifications on Model ST, SB, ESB, RST, RSB and ERSB	2-4
2.3.4	Specifications on Model STC, SBC and ESBC	2-5
2.4	Names of Each Part	2-7
2.4.1	Names of Each Part for Model GM, ST, SB and ESB.....	2-7
2.4.2	Names of Each Part for Model MC, STC, SBC and ESBC.....	2-7
2.4.3	Names of Each Part for Model MR, RST, RSB and ERSB.....	2-8
2.4.4	Special Types	2-8

2.1 Outline of Hand Winch

WARNING

- Do not use it to lift people or to move lifted people laterally. This winch is not appropriate for lifting people on the law, structure and safety.
- When this winch is used for the usage that causes a significant effect on life and property, be sure to install a danger detection unit and an emergency brake other than the winch brake on device side where this winch is mounted.

This hand winch is designed for load lifting or pulling only.

2.2 Winch Overview

1. Easy operation

Our winch is very easy to operate due to its high mechanical efficiency compare with others. This winch compactly designed, is light to carry and easily installed with prescribed bolts. In addition, the main parts are made by press work and the whole of winch is assembled with bolts, so it is easily disassembled. Anyone who has sufficient knowledge can replace parts following this manual.

2. Outstanding durability

Ball bearings are used for all bearings which allow smooth lifting and offer outstanding resistance against wear. For reduction unit, our original gear that has special heat treatment is used. It allows you to work with margin. Due to its system that can adjust the gap as desired, the automatic brake also has outstanding durability. The surface with baking finish resists to rust.

3. Reliable safety

The winch provides the extremely high safety with close examined materials and high quality manufacturing. By combining a precision press-processing rib and/or double plate, the winch has enhanced strength on the parts where load is intensively applied.

The brake is automatically applied on and off with suitable wire rope tension.

Another double safety mechanism is applied to the special drum that ensures an extra maintenance winding for anchoring wire rope. The end of a wire rope can be anchor with attached hex wrench. All those features are our original and designed with high safety.

2.3 Specifications

2.3.1 Specifications on Model GM and MR

Model	GM-1	GM-3	GM-5	GM-10	GM-20	GM-30
	MR-1	MR-3	MR-5	MR-10	MR-20	MR-30
Standard Layer	4th Layer	5th Layer	5th Layer	3rd Layer	3rd Layer	3rd Layer
Load Rating Wire Rope Tension	100kg (220lbs)	300kg (660lbs)	500kg (1,100lbs)	1,000kg (2,200lbs)	2,000kg (4,400lbs)	3,000kg (6,600lbs)
Wire Rope Diameter	φ5mm (6×19) or 3/16inch (7×19)	φ6mm(6×37) or 1/4inch(6×36)	φ6mm(6×37) or 1/4inch(6×36)	φ8mm (6×37) or 5/16inch(6×36)	φ9mm(6×37) or 3/8inch (6×36)	φ12mm (6×37) or 7/16inch (6×36)
Drum Capacity	6-Layer Windings φ 5mm × 35m (3/16inch x 114ft)	6-Layer Windings φ 6mm × 32m (1/4inch x 104ft)	6-Layer Windings φ 6mm × 40m (1/4inch x 131ft)	5-Layer Windings φ 8mm × 35m (5/16inch x 114ft)	5-Layer Windings φ 9mm × 38m (3/8inch x 124ft)	4-Layer Windings φ 12mm × 35m (7/16inch x 114ft)
Gear Ratio	1:1	6.25:1	8.9:1	12.6:1	20:1	35.5:1
Effective Handle Length	250mm (9.84 inch)	250mm (9.84 inch)	250mm (9.84 inch)	300mm (11.81 inch)	370mm (14.57 inch)	370mm (14.57 inch)
Handle Force	21.2kg (46.7lbs)	13.3kg (29.3lbs)	17.7kg (39.0lbs)	18.5kg (40.8lbs)	21.8kg (48.1lbs)	20.5kg (45.2lbs)
Weight (Winch + Handle)	7.2kg (15.9lbs)	14.1kg (31.1lbs)	15.4kg (34.0lbs)	16.4kg (36.2lbs)	28.2kg (62.2lbs)	37.7kg (83.1lbs)
	8.1kg (17.9lbs)	15.0kg (33.1lbs)	16.3kg (35.9lbs)	17.3kg (38.1lbs)	29.1kg (64.2lbs)	38.6kg (85.1lbs)



- The handle forces on above table are the values when set the handle to the maximum length (effective handle length) and wound the rating wire rope tension on the standard winding layers.
- Model GM is a rotational handle winch, and must be installed in a space which allows the handle to be rotated 360 degrees.
- Model MR is a ratchet winch, using left-right motion of the handle to perform lifting and lowering, and can be installed any place. It can also be used as a rotational winch.
- For both Model GM and MR, Type GS that has hot-dip galvanized (referred to as zinc hot dip galvanizing) is available which provides superior resistance to salinity and rust.
For Example, the Model GM-5-GS and MR-20-GS.
*Type GS is not RoHS compliant product.
- Model GM-20 is attached the quick winding handle (gear ratio 4:1, capacity 400kg (880lbs)) in addition to the normal winding handle. Refer to “4.3.2 Handle Operation for Model GM-20 and MC-20” . A quick winding handle is not attached to the Model MR-20.

2.3.2 Specifications on Model MC



Model MC winch is designed only for horizontal pulling. Never use for vertical lifting.

Model	MC-1	MC-3	MC-5	MC-10	MC-20
Load Rating Wire Rope Tension	100kg (220lbs)	300kg (660lbs)	500kg (1,100lbs)	1,000kg (2,200lbs)	2,000kg (4,400lbs)
Wire Rope Diameter	φ5mm (6×19) or 3/16inch (7×19)	φ6mm(6×37) or 1/4inch(6×36)	φ6mm(6×37) or 1/4inch(6×36)	φ8mm (6×37) or 5/16inch(6×36)	φ9mm(6×37) or 3/8inch (6×36)
Gear Ratio	1:1	6.25:1	8.9:1	12.6:1	20:1
Effective Handle Length	250mm (9.84 inch)	250mm (9.84 inch)	250mm (9.84 inch)	300mm (11.81 inch)	370mm (14.57 inch)
Handle Force	12.4kg (27.3lbs)	6.5kg (14.3lbs)	8.5kg (18.7lbs)	10.8kg (23.8lbs)	13.0kg (28.7lbs)
Weight (Winch + Handle)	8.9kg (19.6lbs)	15.8kg (34.8lbs)	17.8kg (39.2lbs)	20.1kg (44.3lbs)	31.3kg (69.0lbs)



• The handle forces on above table are the values when set the handle to the maximum length (effective handle length) and wound the rating wire rope tension on the 1st layer.

• For the Model MC, type GS that has hot-dip galvanized (referred to as zinc hot dip galvanizing) is available which provides superior resistance to salinity and rust.

For Example, the Model MC-3-GS and MC-20-GS.

*Type GS is not RoHS compliant product.

• Model MC-20 is attached the quick winding handle (gear ratio 4:1, capacity 400kg (880lbs)) in addition to the normal winding handle. Refer to “4.3.2 Handle Operation for Model GM-20 and MC-20” .

• For the Model MC winch, the wire rope must be wound around the center of the capstan drum 5 or 7 times, and haul in the wire rope of the same length as the amount that is wound into the drum while the handle is rotated. In order to prevent slippage, tension must be applied to the wire rope while hauling. Refer to the table below for the hauling tension.

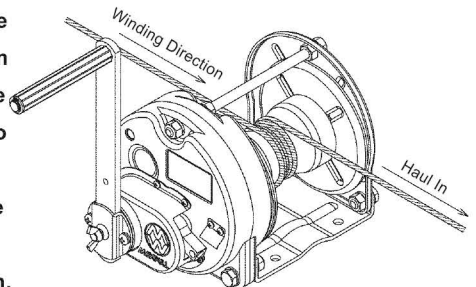

Model	MC-1	MC-3	MC-5	MC-10	MC-20
Hauling Tension	2kg or more (4.4lbs or more)	4kg or more (8.8lbs or more)	7kg or more (15.4lbs or more)	13kg or more (28.7lbs or more)	25kg or more (55.1lbs or more)

*Hauling tension values in the above table is with the wire rope wound 7 times around the capstan drum.

2.3.3 Specifications on Model ST, SB, ESB, RST, RSB and ERSB

Model	Rotating-Handle	Metallic Painting	ST-1	ST-3	ST-5	ST-10
		Buffing	SB-1	SB-3	SB-5	SB-10
		Electropolishing	ESB-1	ESB-3	ESB-5	ESB-10
	Ratchet-Handle	Metallic Painting	RST-1	RST-3	RST-5	RST-10
		Buffing	RSB-1	RSB-3	RSB-5	RSB-10
		Electropolishing	ERSB-1	ERSB-3	ERSB-5	ERSB-10
Standard Layer		4th Layer	5th Layer	5th Layer	3rd Layer	
Load Rating Wire Rope Tension		100kg (220lbs)	300kg (660lbs)	500kg (1,100lbs)	1,000kg (2,200lbs)	
Wire Rope Diameter		φ5mm (6×19) or 3/16inch (7×19)	φ6mm(6×37) or 1/4inch(6×36)	φ6mm(6×37) or 1/4inch(6×36)	φ8mm (6×37) or 5/16inch(6×36)	
Drum Capacity		6-Layer Windings φ 5mm × 35m (3/16inch x 114ft)	6-Layer Windings φ 6mm × 32m (1/4inch x 104ft)	6-Layer Windings φ 6mm × 40m (1/4inch x 131ft)	5-Layer Windings φ 8mm × 35m (5/16inch x 114ft)	
Gear Ratio		1:1	6.25:1	8.9:1	12.6:1	
Effective Handle Length		250mm (9.84 inch)	250mm (9.84 inch)	250mm (9.84 inch)	300mm (11.81 inch)	
Handle Force		21.2kg (46.7lbs)	13.3kg (29.3lbs)	17.7kg (39.0lbs)	18.5kg (40.8lbs)	
Weight (Winch + Handle)		7.4kg (16.3lbs)	14.3kg (31.5lbs)	15.6kg (34.4lbs)	16.6kg (36.6lbs)	
		9.0kg (19.8lbs)	15.9kg (35.1lbs)	17.2kg (37.9lbs)	18.2kg (40.1lbs)	



- The handle forces on above table are the values when set the handle to the maximum length (effective handle length) and wound the rating wire rope tension on the standard winding layers.
- The models ST, SB and ESB are a rotational handle winch, and must be installed in a space which allows the handle to be rotated 360 degrees.
- The models RST, RSB and ERSB are a ratchet winch, using left-right motion of the handle to perform lifting and lowering, and can be installed any place. It can also be used as a rotational winch.
- The models ST and RST have a metallic coating. After cleaning the stainless steel surface, it has been baked and coated for excellent rust prevention.
- The models SB and RSB have a buffed surface. The stainless steel surfaces are manually polished with a buffing compound to achieve the beauty and chemical resistance of the stainless steel.
- The surfaces of models ESB and ERSB are electrolytically polished. By immersing the surface of stainless steel parts into an electrolytic solution and running electrical power on them, a glossy film is formed on the surface of the stainless steel. This makes the product salt-resistant and rust-proof. This process provides excellent performance and better chemical resistance than models SB and RSB.

2.3.4 Specifications on Model STC, SBC and ESBC



Model STC, SBC and ESBC winches are designed only for horizontal pulling. Never use for vertical lifting.

Model	Metallic Painting	STC-1	STC-3	STC-5	STC-10
	Buffing	SBC-1	SBC-3	SBC-5	SBC-10
	Electropolishing	ESBC-1	ESBC-3	ESBC-5	ESBC-10
Load Rating Wire Rope Tension		100kg (220lbs)	300kg (660lbs)	500kg (1,100lbs)	1,000kg (2,200lbs)
Wire Rope Diameter		φ5mm (6×19) or 3/16inch (7×19)	φ6mm(6×37) or 1/4inch(6×36)	φ6mm(6×37) or 1/4inch(6×36)	φ8mm (6×37) or 5/16inch(6×36)
Gear Ratio		1:1	6.25:1	8.9:1	12.6:1
Effective Handle Length		250mm (9.84 inch)	250mm (9.84 inch)	250mm (9.84 inch)	300mm (11.81 inch)
Handle Force		12.4kg (27.3lbs)	6.5kg (14.3lbs)	8.5kg (18.7lbs)	10.8kg (23.8lbs)
Weight (Winch+Handle)		9.1kg (20.1lbs)	16.0kg (35.3lbs)	18.0kg (39.7lbs)	20.3kg (44.8lbs)



- The handle forces on above table are the values when set the handle to the maximum length (effective handle length) and wound the rating wire rope tension on the 1st layer.
- The model STC has a metallic coating. After cleaning the stainless steel surface, it has been baked and coated for excellent rust prevention.
- The model SBC has a buffed surface. The stainless steel surfaces are manually polished with a buffing compound to achieve the beauty and chemical resistance of the stainless steel.
- The surface of model ESBC is electrolytically polished. By immersing the surface of stainless steel parts into an electrolytic solution and running electrical power on them, a glossy film is formed on the surface of the stainless steel. This makes the product salt-resistant and rust-proof. This process provides excellent performance and better chemical resistance than models SBC.

- For the models STC, SBC and ESBC winches, the wire rope must be wound around the center of the capstan drum 5 or 7 times, and haul in the wire rope of the same length as the amount that is wound into the drum while the handle is rotated. In order to prevent slippage, tension must be applied to the wire rope while hauling. Refer to the table below for the hauling tension.

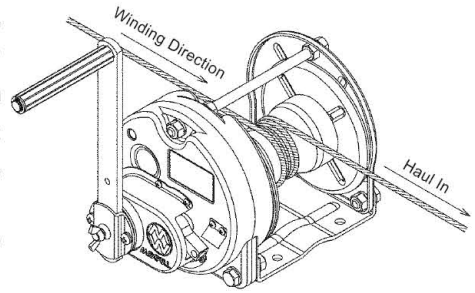

Model	Metallic Painting	STC-1	STC-3	STC-5	STC-10
	Buffing	SBC-1	SBC-3	SBC-5	SBC-10
	Electropolishing	ESBC-1	ESBC-3	ESBC-5	ESBC-10
Hauling Tension		2kg or more (4.4lbs or more)	4kg or more (8.8lbs or more)	7kg or more (15.4lbs or more)	13kg or more (28.7lbs or more)

*Hauling tension values in the above table is with the wire rope wound 7 times around the capstan drum.

2.4 Names of Each Part

2.4.1 Names of Each Part for Model GM, ST, SB and ESB

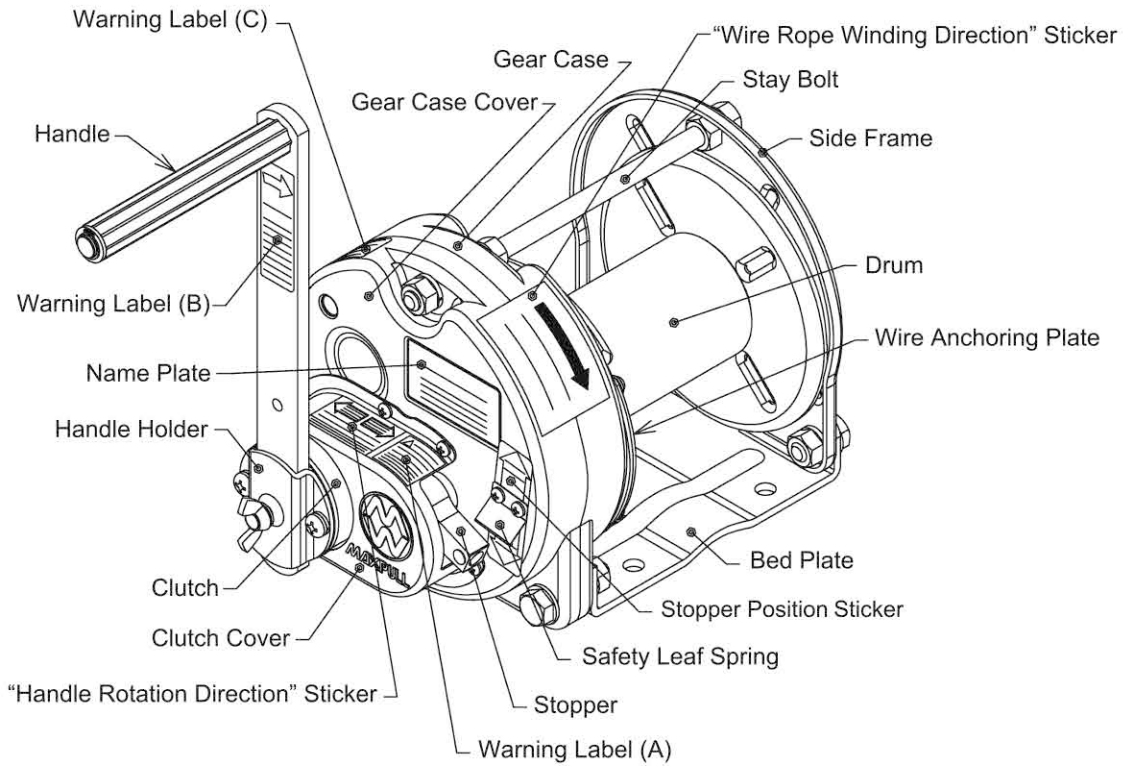

2.4.2 Names of Each Part for Model MC, STC, SBC and ESBC

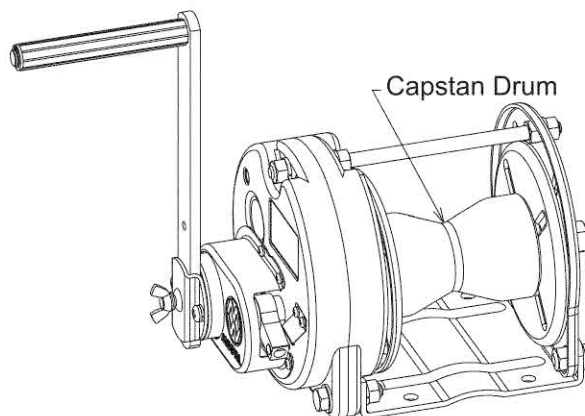

• Parts and units that are not described is same as Model GM, ST, SB and ESB.

2.4.3 Names of Each Part for Model MR , RST, RSB and ERSB

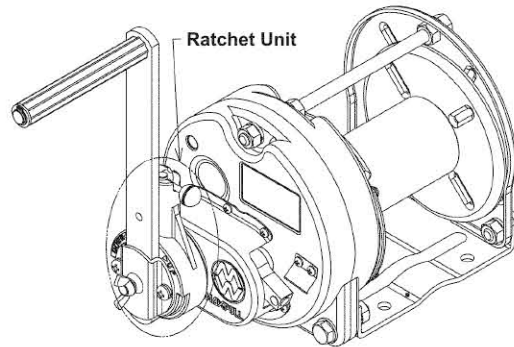

• Parts and units that are not described is same as Model GM, ST, SB and ESB.

2.4.4 Special Types

1. Stopper Armless (Type SI)

Stopper unit is covered with the clutch cover to prevent an accidental operation.

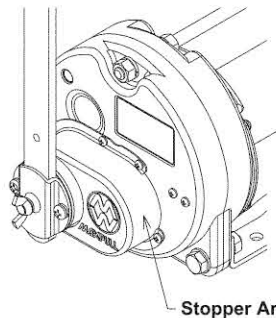

• This stopper unit can be mounted to Model GM, MC, MR, ST, SB, ESB, STC, SBC, ESBC, RST, RSB and ERSB.
For Example, the Model GM-5-SI, MC-10-SI and MR-20-SI.

2. Noiseless Mechanism (Type NSIL)

Silent lifting and lowering is possible with this unit.

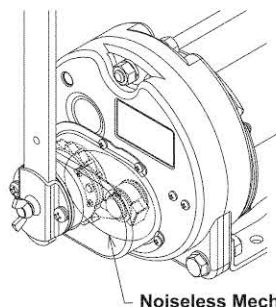

• This unit can be mounted to Model GM and MC.
For Example, the Model GM-1-NSIL and MC-10-NSIL.

• Due to the non-magnetic material of stainless steel, (Type NSIL) cannot be manufactured.

• The noiseless mechanism (Type NSIL) on the model MR does not work due to the clicking sound generated from the ratchet handle.

3. Dust and Drip-proof Brake (Type SIC)

Entire brake unit is dust and drip-proof.

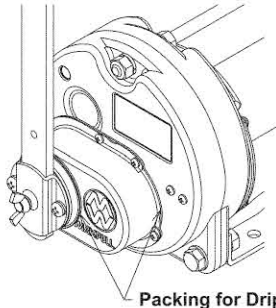

- This stopper unit can be mounted to Model GM, MC, MR, ST, SB, ESB, STC, SBC, ESBC, RST, RSB and ERSB.

For Example, the Model GM-5-SIC, MC-10-SIC and MR-20-SIC.

Chapter 3 INSTALLATION

- 3.1 Installation Outline 3-1
- 3.2 Unpacking 3-1
- 3.3 Inspection of Components and Attachments 3-1
- 3.4 Selection of Setting Site 3-1
- 3.5 Installation of the Winch 3-2
- 3.6 Installation of the Pulley 3-4
- 3.7 Anchoring of the Wire Rope 3-5
 - 3.7.1 Anchoring the Wire Rope for Model GM-1 to GM-10, MR-1 to MR-10,
ST-1 to ST-10, SB-1 to SB-10, ESB-1 to ESB-10, RST-1 to RST-10,
RSB-1 to RSB-10 and ERSB-1 to ERSB-10 3-6
 - 3.7.2 Anchoring the Wire Rope for Model GM-20 and MR-20 3-7
 - 3.7.3 Anchoring the Wire Rope for Model GM-30 and MR-30 3-8

3.1 Installation Outline

In order to demonstrate the performance of the hand winch fully, only engineers who are skilled in operation, safety management and maintenance management must do the installation. The installation work includes the following contents:

- ① Unpacking Section 3.2
- ② Inspection of Components and Attachments . . . Section 3.3
- ③ Selection of Setting Site Section 3.4
- ④ Installation of the Winch Section 3.5
- ⑤ Installation of the Pulley Section 3.6
- ⑥ Anchoring of the Wire Rope Section 3.7

3.2 Unpacking



- **To avoid danger, keep babies and children from the enclosed plastic bag, winch, and other parts and accessories.**
- **Only use genuine winch product parts and accessories.**

Unpacking the components and check that all items are as per the contents of the parts specifications. If not, contact MAXPULL for confirmation.

3.3 Inspection of Components and Attachments

Check the appearance of each component and attachment for any damage described below:

- ① Any dent or damage during transportation
- ② Missing parts
- ③ Loosen bolts or nuts



- **If the winch, parts and accessories of the winch are lost or damaged, contact MAXPULL MACHINERY & ENGINEERING CO., LTD. or your local distributor to order replacement. Provide the winch model, serial number, and the part number on Appendix 2.**

3.4 Selection of Setting Site

Install the winch in consideration of the following points:

- ① The large safe area where inspection and maintenance can be conducted easily.
- ② The large area where the load and the wire rope can be observed during the operation.
- ③ The area where the fleet angle of 2 degrees or less can be ensured to the pulley.

Install and use the winch in the special environments described below must be avoided due to a extreme danger.

- The winch can not be installed or used in locations of -10°C (14°F) or lower. Using the winch in temperature below -10°C (14°F) will result in increased the cold brittleness of metals and degradation in winch grease, which may result in accidents.
- Environments with ambient temperature of 40°C (104°F) or higher, or with humidity of 90% or higher.
- Dusty, greasy areas or areas requiring waterproofing.
- Environments with high acidity or salinity.
- Outdoors with exposure to wind, rain or snow.



- Consult with MAXPULL before using the winch in one of the special environments described above.
- When installing the winch in outdoors where it will be exposed to wind, rain and/or snow, we highly recommend to cover the winch with waterproof cover to prevent corrosion.
- For environments which especially require resistance to salinity or corrosion, the stainless steel winch Model ST, SB, ESB or type GS with the hot-dip galvanized are recommended (referred to as zinc hot dip galvanizing).
- Winches installed in area with large temperature fluctuations may have condensation within the gear case or brake unit, and this condensation and the grease applied to inside gears and other sliding parts becomes liquid, resulting in leaking from the gear case seam. For this reason, a tray may be needed to catch the liquid for some installation space.

3.5 Installation of the Winch

This section explains the procedures to install the winch.



Only qualified personnel who are installation specialist or have sufficient knowledge of installation can perform installation.

- 1) Transport the winch to installation point where the load and the wire rope can be observed during the operation, and inspection and maintenance can be conducted easily.



Be sure not to drop or fall over the winch.

- 2) Set the winch height to easy-work-height.



If the center of the handle rotation (clutch) is at the level of the operator's waist, it is the easiest height for operation.

- 3) Fix the winch to the installation base with specified bolts and nuts.



- If there are any gaps between the bed plate and installation base, insert a shim plate.

- Welding the winch bed plate may result in loss of winch accuracy, which may not only be the cause of accidents but also make it impossible to perform maintenance.

- 4) Check that the fleet angle is within 2 degrees to the pulley.



- The fleet angle is the angle formed with a perpendicular line from the pulley to the drum and the line between the pulley and the drum plate shown below.

- When the drum center line and the pulley center line align on the same line as shown below, the fleet angle is within 2 degrees as long as the distance "L" between the drum and the pulley is 15 times or greater than "W".

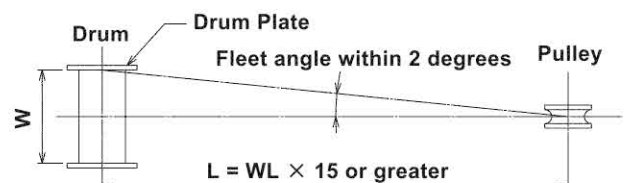

- When the drum center line and the pulley center line are not the same as shown below, the fleet angle is within 2 degrees as long as the distance “L” between the drum and the pulley is 30 times or greater than the wider length “WL” .

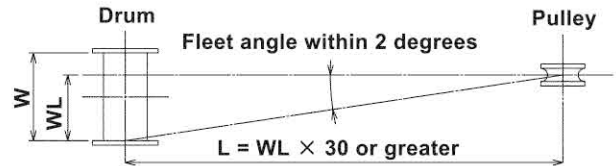

- When the fleet angle is not properly secured, the wire rope may not be wound to the drum correctly, which may result in the wire rope being damaged, or shortening the lifespan of the wire rope.
Also wire rope slippage may result in sudden load shock, causing the wire rope to break, damage or breakage of the winch.

- 5) If the “Handle Rotation Direction” sticker on the clutch cover cannot be seen after the winch installation, order a replacement sticker from MAXPULL at your own cost and affix it in a visible location.

3.6 Installation of the Pulley

This section explains the procedures to install the pulley.

- 1) Prepare a smoothly rotated pulley with a diameter (pitch diameter) of 15 times or greater than the diameter of the wire rope.
- 2) Take preventive measures against the wire rope slipping off on the pulley.
- 3) Set the pulley to the position where the fleet angle is 2 degrees or less to the winch.



Refer to “3.5 Installation of the Winch”.

3.7 Anchoring of the Wire Rope

This section explains the procedures to anchor the wire rope end to the winch drum.

DANGER

- **Pass the end of the wire rope through a hole for the extra maintenance winding on the drum, and anchor the end of the wire rope with no gaps in extra maintenance winding from the hole to the drum side plate that has the wire lock unit. If there is no extra maintenance winding, a high load will be placed directly on the wire rope anchoring point, which may result in serious accident with loose wire rope.**
- **Always rotate the handle to the right (clockwise) to wind the wire rope. If the wire rope is wound in the opposite direction, the brake unit does not function at all resulting in serious accident.**



- The procedure of anchoring the end of the wire rope is slightly different for each winch model.
- The end of the wire rope is not anchored for Model MC, STC, SBC and ESBC.
- For winches with rated loads of 100kg(220lbs) to 2,000kg(4,400lbs), when the handle is rotated right (clockwise), the drum also rotates clockwise to wind the wire rope.
- For winches with a rated load of 3,000kg(6,600lbs), when the handle is rotated right (clockwise), the drum rotates left (counterclockwise) to wind the wire rope.

3.7.1 Anchoring the Wire Rope for Model GM-1 to GM-10, MR-1 to MR-10, ST-1 to ST-10, SB-1 to SB-10, ESB-1 to ESB-10, RST-1 to RST-10, RSB-1 to RSB-10 and ERSB-1 to ERSB-10

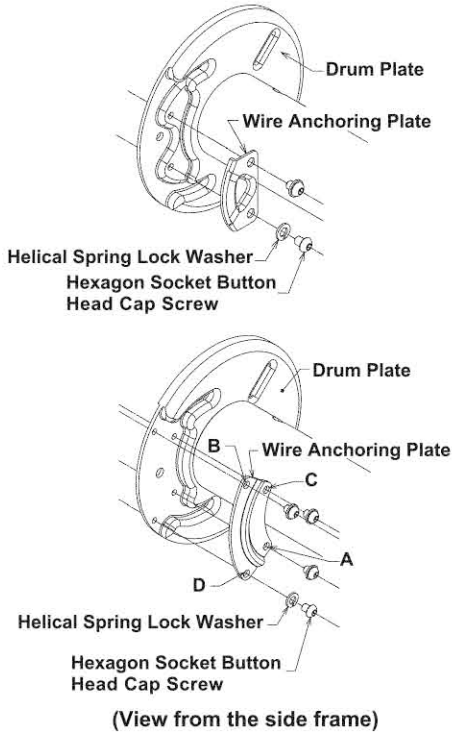

1) As shown in the left figure, loosen the hexagon socket button head cap screw M6×10 (with helical spring lock washer) on the wire rope anchoring point, and remove the wire anchoring plate.



- There are two hexagon socket button head cap screws M6×10 (with helical spring lock washers) for GM-1, MR-1, GM-3 and MR-3.
- Even the wire rope diameter for Model GM-1, MR-1, ST-1, SB-1, ESB-1, RST-1, RSB-1 and ERSB-1 are $\phi 5\text{mm}$ (3/16inch), and for Model GM-3, MR-3, ST-3, SB-3, ESB-3, RST-3, RSB-3 and ERSB-3 are $\phi 6\text{mm}$ (1/4inch), the wire anchoring plate is in common.
- Model GM-5, MR-5, ST-5, SB-5, ESB-5, RST-5, RSB-5 and ERSB-5 have a wire rope diameter of $\phi 6\text{mm}$ (1/4inch) and use a specified wire anchoring plate.
- Model GM-10, MR-10, ST-10, SB-10, ESB-10, RST-10, RSB-10 and ERSB-10 have a wire rope diameter of $\phi 8\text{mm}$ (5/16inch) and use a specified wire anchoring plate.

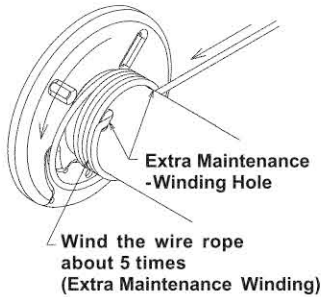

2) As shown in the left figure, pass the end of the wire rope through a hole for the extra maintenance winding on the drum in the direction indicated by the arrow, and pull the wire rope.



- For the length of the wire rope to be pulled out and the winding number, refer to the table below.

Model	Applicable Wire Rope Diameter	Pulling out Length	Winding Number
GM-1, MR-1, ST-1, SB-1, ESB-1, RST-1, RSB-1, ERSB-1	$\phi 5\text{mm}$ (3/16inch)	1.2m (3.9ft)	5.5windings
GM-3, MR-3, ST-3, SB-3, ESB-3, RST-3, RSB-3, ERSB-3	$\phi 6\text{mm}$ (1/4inch)	1.0m (3.3ft)	4.5windings
GM-5, MR-5, ST-5, SB-5, ESB-5, RST-5, RSB-5, ERSB-5	$\phi 6\text{mm}$ (1/4inch)	1.5m (4.9ft)	5.5windings
GM-10, MR-10, ST-10, SB-10, ESB-10, RST-10, RSB-10, ERSB-10	$\phi 8\text{mm}$ (5/16inch)	1.3m (4.3ft)	4.5windings

3) Wind the pulled wire rope to the direction shown in the figure at the step 2).

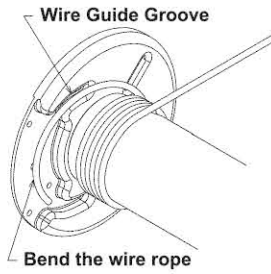

4) As shown in the left figure, bend the end of the wire rope about 6 or 7cm(2.4 or 2.8inch) using pliers to fit the groove of the wire anchoring plate.

5) Cover the end of the wire rope with the wire anchoring plate after fitting the wire rope to the wire guide groove on the drum plate.



There is no wire guide groove on the drum plate of Model GM-1, MR-1, ST-1, SB-1, ESB-1, RST-1, RSB-1 and ERSB-1.

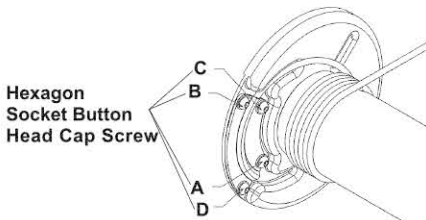

6) As shown in the left figure, tighten the wire anchoring plate with 4 hexagon socket button head cap screws M6×10(with helical spring lock washers) and anchor the end of the wire rope to the drum.



To tighten the wire anchoring plate, tighten the screws A and B temporarily which is in diagonal position without using spring washers first. Then, set the spring washers at C and D position and tighten securely. Remove the temporary screws at A and B, and set the spring washers to tighten A and B securely. It is the easy way to tighten the wire anchoring plate.

3.7.2 Anchoring the Wire Rope for Model GM-20 and MR-20

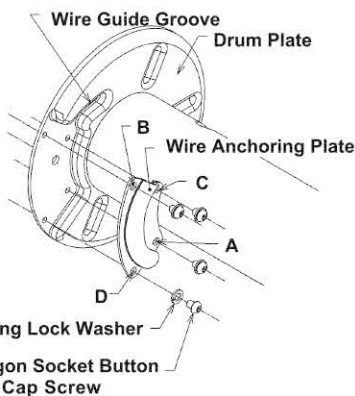

(View from the side frame)

1) Remove diagonal 2 of 4 hexagon socket button head cap screws M6×10 (with helical spring lock washers) at C and D set at the wire rope anchoring point on the drum, and adjust two other screws at A and B to loosen the wire anchoring plate enough to allow the wire rope to be inserted.

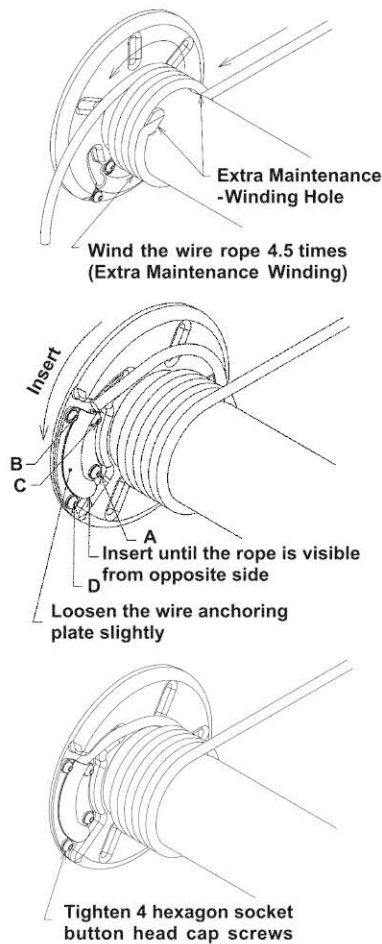

- 2) As shown in the left figure, pass the end of the $\phi 9\text{mm}$ (3/8 inch) wire rope through a hole for the extra maintenance winding on the drum in the direction indicated by the arrow, pull the wire rope about 1.4m (4.6 ft) and wind to the drum plate side 4.5 times.
- 3) Push the end of the wound wire rope from the wire guide groove to the opposite side.
- 4) Tighten the two screws (with spring washers) at C and D securely after tightening two screws at A and B to anchor the end of the wire rope.
- 5) Lastly, check that the screws M6×10 (with spring washers) set to the wire anchoring plate are for secure tightening, and retightening those four screws.



To tighten the wire anchoring plate, tighten the screws A and B temporarily which is in diagonal position without using spring washers first. Then, set the spring washers at C and D position and tighten securely. Remove the temporary screws at A and B, and set the spring washers to tighten A and B securely. It is the easy way to tighten the wire anchoring plate.

3.7.3 Anchoring the Wire Rope for Model GM-30 and MR-30

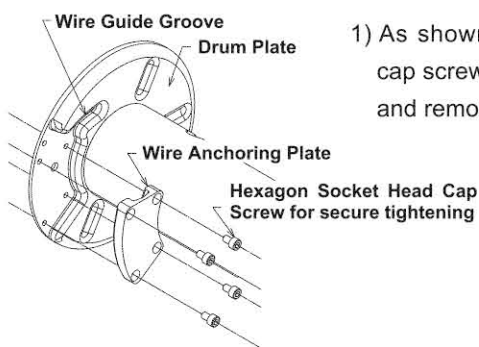

(View from the gear case side)

- 1) As shown in the left figure, loosen the hexagon socket head cap screws for secure tightening using the attached hex wrench, and remove the wire anchoring plate.

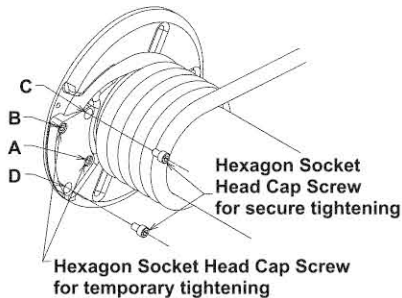
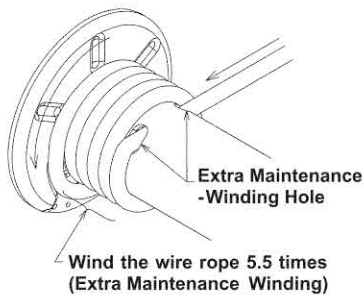

- 2) As shown in the left figure, pass the $\phi 12\text{mm}$ (7/16inch) wire rope through a hole for the extra maintenance winding on the drum, in the direction indicate by the arrow pull the wire rope about 1.8m (5.9ft) and wind to the drum plate side 5.5 times.
- 3) As shown in the left figure, insert the end of the wound wire rope to the anchoring plate groove, then temporarily tighten with attached two temporary hexagon socket head cap screws M6 \times 15 onto the tightening hole A and B on the anchoring plate. Then, securely tighten the removed two hexagon socket head cap screws M6 \times 10 to the tightening hole C and D.
- 4) Remove the two temporary hexagon socket head cap screws from the tightening hole A and B to replace with the two hexagon socket head cap screws M6 \times 10 for secure tightening.
- 5) Lastly, check that the four hexagon socket head cap screws are for secure tightening, and retightening those four screws.

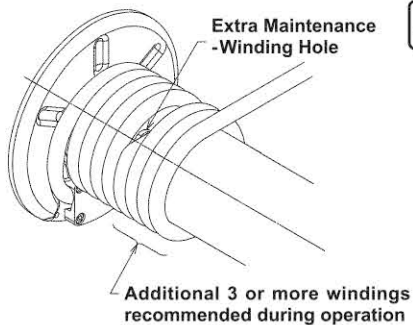

The extra maintenance winding from the extra maintenance winding-hole to the drum side plate is secured. However, for maximum safety, additional three or more windings are recommended for Model GM-30 or MR-30 which allows large load.

Chapter 4 OPERATION

4.1	Inspection before Operation	4-1
4.1.1	Checking the Stopper Arm Position	4-1
4.1.2	Checking the Brake Operation	4-2
4.1.3	Checking the Wire Rope Winding Direction	4-2
4.2	Fastening of Handle	4-3
4.3	Handle Operation	4-3
4.3.1	Ratchet Handle Operation for Model MR, RST, RSB and ERSB.....	4-4
4.3.2	Handle Operation for Model GM-20 and MC-20	4-5
4.3.3	Handle Operation with the Load Lifted up (Exclude Model MR, RST, RSB and ERSB) ..	4-6
4.3.4	Winding Direction	4-7

4.1 Inspection before Operation

⚠ DANGER

- Check the following items before winch operation.
 - Make sure that the winch is securely installed.
If not, it could cause accidents or malfunction of the winch.
 - Make sure that the load is equal to or less than the rated load.
Ignoring this could cause accidents or malfunction of the winch.
 - The winding direction of the wire rope is same as the direction on the sticker affixed on the winch.
Wind the wrong direction will result in no functioning of brake and serious accidents or injuries due to the load falling.
 - Make sure that the stopper arm is set to the “lifting” position.
(Exclude the Type SI, SIC and NSIL. Refer to “2.4.4 Special Types”.)
 - Make sure that the end of the wire rope is anchored to the drum correctly and the certain amount of extra maintenance winding has been done.
 - Make sure that the fleet angle of 2 degrees or less is secured.
 - Make sure that there is no broken element wires, worn down of the diameter, kink, excessive deform and/or corrosion on the wire rope.
 - Make sure there are no damaged parts or other conditions that may affect the operation of the winch.

4.1.1 Checking the Stopper Arm Position

⚠ DANGER

- If the stopper arm is at position “B”, the brake is not applied.
- Do not move the stopper arm from the position “A” while the winch is under load.

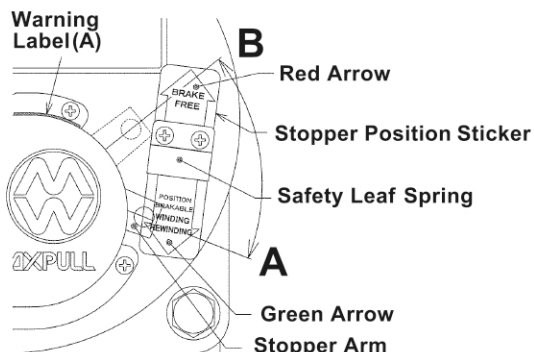

Check that the stopper arm is at the position “A” in the figure.



The Type SI, SIC and NSIL are excluded. Refer to “2.4.4 Special Types”.

4.1.2 Checking the Brake Operation

Check that the brake operates normally.

1. With load

Turning the handle to the lifting direction (right rotation in view of the winch front: clockwise) makes a clicking sound. Turning the handle to the lowering (counterclockwise) does not make sound. When the winch always makes clicking sound by turning the handle to the lifting direction for 3 or 4 times, the brake unit operates correctly.



• For the models with ratchet handle, operate the handle by setting the switch lever to “Lifting/Lowering”. Refer to “4.3.1 Ratchet Handle Operation for Model MR, RST, RSB and ERSB”.

• Type NSIL, noiseless mechanism, does not make a clicking sound.

2. Without load

The brake unit is designed not to function without load. When inspecting without load, turn the drum with both hands. When the drum turns to the direction indicated on the sticker as an arrow which the wire rope winding direction (clockwise) and the drum does not turn to the opposite direction (counterclockwise), the brake operates correctly. Repeat turning the drum for 3 or 4 times to make sure the drum does not turn to the reverse direction.



For Model GM-30 and MR-30, the drum turns to the opposite direction as the handle. Therefore, when the drum turns to the direction indicated on the sticker as an arrow which the wire rope winding direction (counterclockwise) and does not turn to the opposite direction (clockwise), the brake operates correctly.

CAUTION Remove the handle before turning the drum by hands.

4.1.3 Checking the Wire Rope Winding Direction

Lifting direction in view of the winch front is right for both the handle and the drum.



For Model GM-30 and MR-30, lifting direction in view of the winch front is right for the handle and left for the drum.

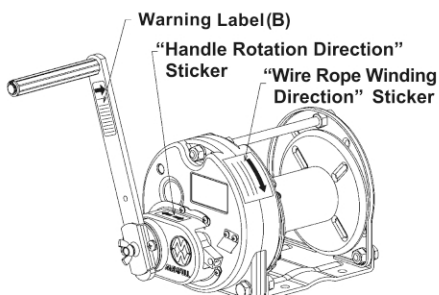

1) Turn the handle to the lifting direction following the sticker affixed on the winch.

2) Check that the wire rope is wound into the drum.

4.2 Fastening of Handle

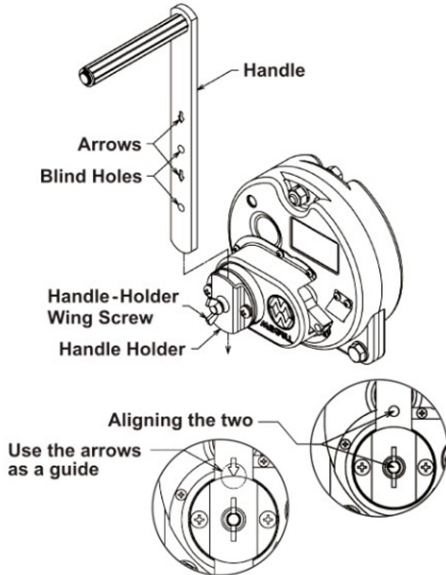

- 1) Loosen the handle-holder wing screw as shown in the left figure.
- 2) Insert the handle to the handle-holder.
- 3) Align the arrow with the edge of the handle holder for easier positioning.
- 4) Securely tighten the handle-holder wing screw to the blind hole.



- Do not attach the handle at any position other than the blind hole.
- If handle-holder wing screw is loosened during operation, retighten the wing screw before continuing the operation.

4.3 Handle Operation

⚠ DANGER

- Follow the items below for winch operation.

- Keep all personnel away at safe distances from 1) operating winches, 2) under loads, 3) transverse areas, and 4) areas near the wire rope to avoid potential breaks.
- Never stand 1) under loads, 2) transverse areas, or 3) areas near the wire rope to avoid potential breaks.
- Never attempt to distract operators from the loads or winch in transverse motion or lifting.
- Never attempt to extend the length of the handle, to hang the handle putting one's weight or to operate the handle with stepping on it. Doing so may result in damages to the winch and brake unit, or breakage of the wire rope that cause the fall of the loads.
- Do not jerk or swing the load. Never exceed the maximum load capacity specified for each model and operate the winch slowly during the starting and stopping point.
- Never operate the winch with a motor of any kind. Only use your hands.
- Never attempt to exceed the load limit indicated on the winch or any other component in the system.
- Never attempt to invert the load or to hook the load to the structures and/or other objects.
- Do not use the winch for lateral work in the places where the surface has declivity due to the malfunction of the brake unit.
- Make sure that the winch is locked before releasing handle.

⚠ WARNING

- The lifting operation must start after checking that the load is in good condition and brake does not slip . The check has to be done with temporary stop of the operation of the winch with tension on the wire rope.
- Make sure that the wire rope is long enough to the lifting length and there is sufficient length of extra maintenance winding even after the load is completely lowered.
- Brake slippage may occur under conditions that the load does not free fall vertically or the load is too small for the rated load.
- Always operate the winch with securely tighten the handle-holder wing screw to the blind hole.
- Always rotate the handle clockwise to wind the wire rope onto the drum.
If the wire rope winds onto the drum when the handle is rotated counterclockwise, the brake will not work and could cause an accident.

4.3.1 Ratchet Handle Operation for Model MR, RST, RSB and ERSB

Follow the procedures to operate the ratchet handle for Model MR, RST, RSB and ERSB.



- Originally, Model MR, RST, RSB and ERSB have been designed for use in locations where its handle cannot rotate 360 degree. However, the model can be used as a rotation type like Model GM, ST, SB and ESB.
- A quick winding handle is not attached to Model MR-20 due to its mechanism.
- Model MR, RST, RSB and ERSB cannot operate normally without load.
Five percent or more of the rated load is necessary for normal handle operation.

1. Lowering operation

Reciprocating Operation of the Handle

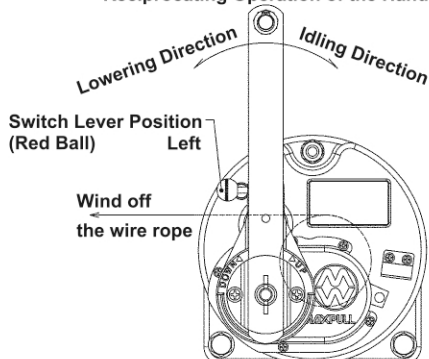

- 1) Set the switch lever (red ball) to left in view of winch front.
- 2) Reciprocate the handle to the right and left.
→ The wire rope is wound off from the drum each time the handle moves to the left.

2. Lifting operation

Reciprocating Operation of the Handle

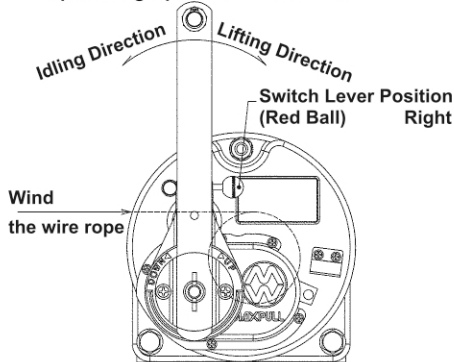

- 1) Set the switch lever (red ball) to right in view of winch front.
- 2) Reciprocate the handle to the right and left.
→ The wire rope is wound into the drum each time the handle moves to the right.

4.3.2 Handle Operation for Model GM-20 and MC-20

Follow the procedure below for the handle operation for Model GM-20 and MC-20.



- A normal winding handle and a quick winding handle are attached to Model GM-20 and MC-20 (including the Type SI, SIC and NSIL).
- Model MC-20 is used for horizontal pulling only. The words “lifting” and “lowering” in the context should be referred as “wind” and “rewind”.

1. Normal winding operation

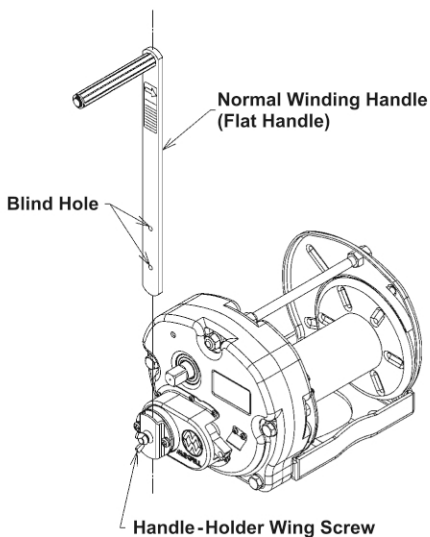

(Handle for Model GM-20 and MC-20)

The normal winding handle (flat handle) lifts by right rotation (clockwise) and lowers by left rotation (counterclockwise).
Load rating : Max. wire rope tension is 2,000kg(4,400lbs) , Gear ratio is 20:1.

2. Quick winding operation

⚠ DANGER

Never attempt to lower by right rotation (clockwise) with a quick winding handle while the stopper arm is set at “Brake Free” position.

This may cause accidents due to the malfunction of the brake.

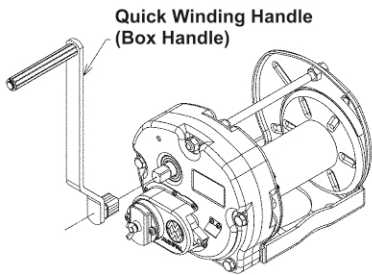

(Handle for Model GM-20 and MC-20)

The quick winding handle (box handle) lifts by left rotation (counterclockwise). Usually this handle cannot lower.
Load rating at counterclockwise : Max. wire rope tension is 400kg (880lbs) , Gear ratio is 4:1.



This handle is used only when lifting the light load rapidly.

4.3.3 Handle Operation with the Load Lifted up (Exclude Model MR , RST, RSB and ERSB)

Follow the procedures below to prevent the fall of the load in the case that the lifted load is held for a long period of time.

⚠ WARNING

- **When the load is kept lifted for a long period of time, apply another effective brake unit or lock unit other than the main brake unit on the winch.**
- **Do not leave a suspended load without specified instructions to secure the load. Keep people away from the winch and under the suspended load.**

1) Loosen the handle-holder wing screw.

2) Remove the handle from the handle holder.

3) Reverse the handle (the grip faces to the drum) and insert to the handle holder.

4) Securely tighten the handle-holder wing screw to the handle.

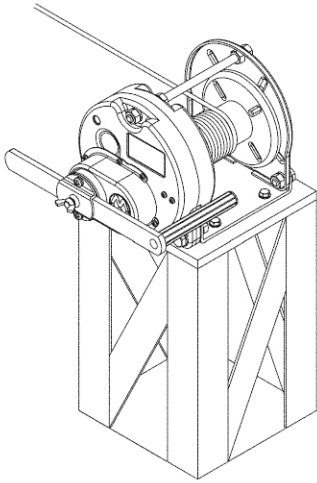

(Regular installation)

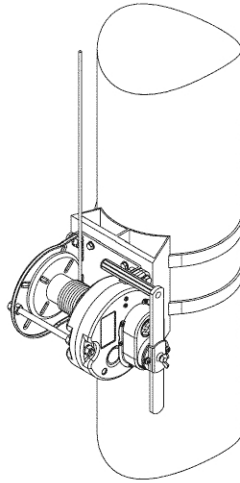

(Winch installation to a pole,
Wire rope pulled from the right)

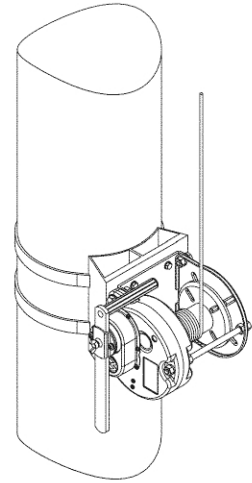

(Winch installation to a pole,
Wire rope pulled from the left)

4.3.4 Winding Direction



Always rotate the handle clockwise to wind the wire rope onto the drum.

If the wire rope winds onto the drum when the handle is rotated counterclockwise, the brake will not work.

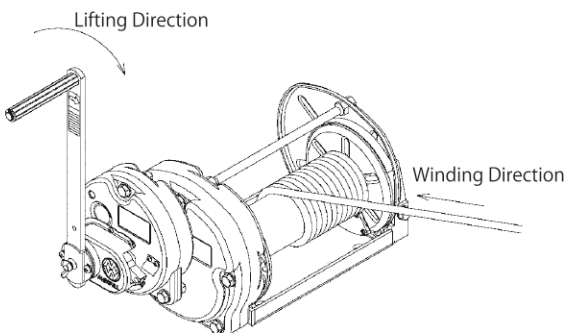

Winch of Load Rating of **3,000kg(6,600lbs)**

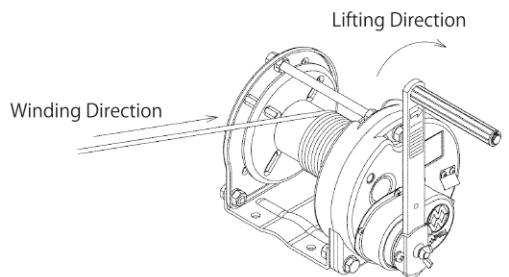

Winch of Load Rating from **100kg(220lbs)** to **2,000kg(4,400lbs)**

Chapter 5 INSPECTION / SERVICE / MAINTENANCE

5.1	Inspection / Service	5-1
5.1.1	Daily Inspection	5-1
5.1.2	Periodical Inspection	5-2
5.2	Maintenance	5-8
5.2.1	Troubleshooting and its measures	5-8

5.1 Inspection / Service

Inspection and service are required to operation the winch with maximum safety, and to keep the high quality on MAXPULL winch. Inspection and service include “Daily Inspection” which is required before the operation and “Periodical Inspection” which is required disassembly and inspection of the mechanical brake unit added to the “Daily Inspection”.

WARNING

- **All loads must be lowered before any inspection and/or service and make sure that there is no load on the wire rope and the winch.**
- **Only qualified personnel with designated knowledge can perform the inspection and service.**
- **Post a tag or placard stating “UNDER INSPECTION WORK” to prevent the winch being operated accidentally by the other personnel during the inspection or service work.**
- **Never attempt to operate the winch without “Daily Inspection”.**

5.1.1 Daily Inspection

“Daily Inspection” is necessary before the winch operation.



For detail of the items on the “Daily Inspection”, refer to “Appendix 1. MAXPULL Winch Inspection Sheet”.

5.1.2 Periodical Inspection

Periodically disassemble and inspect the mechanical brake unit.



- When dust, obstacles or water get into the brake unit, it may cause the malfunction of the brake unit. Disassemble and inspect the brake unit periodically.

Indoor : Annually

Outdoor : Every 6 months

Dusty area : Every 3 months

There are slight differences depending on the installation site and/or frequency of usage.

- The mechanical brake unit may not work properly when the winch is not being used or left for a long period of time. Operate the winch once in every 2 weeks. When the winch is used after leaving for a long period of time, make sure to disassemble and inspect the mechanical brake unit before the operation.



For detail of the items on the “Periodical Inspection”, refer to “Appendix 1. MAXPULL Winch Inspection Sheet”.

1. Disassembly and inspection of the brake unit



For the structure of each winch, refer to “Appendix 2. Parts List for Each Model”



- Continuous lowering operation with load gives heat to the brake unit. It does not affect to the function, but take some time to cool the brake unit down before disassembly.

- Be sure not to lose any small parts removed from the mechanical brake unit.

- 1) Make sure that there is no load on the wire rope and the winch.



Remove any tension on the wire rope wound to the drum by lowering the load or using the wire stretcher.

- 2) Remove the handle, two phillips pan head screws (No.56), and handle holder (No.25).

Disassembly of the ratchet unit is necessary for Model MR, RST, RSB and ERSB (ratchet model).

- 3) Remove the two hexagon socket head cap screws M6×15 (No.77) and ratchet handle (No.73).



• **Set the switch lever (No.74) to the neutral position (on the winch side).**

• **For Model GM, MC, ST, SB, ESB, STC, SBC and ESBC (rotation model), skip this step 3) and 4).**

- 4) Remove the two hexagon socket head cap screws M8×15 (No.72), ratchet wheel (No.71) and axis (No.70).



The ratchet wheel and the axis have front and back side. Be careful not to assemble wrongly.

- 5) Dismount the clutch shield plate (No.26).



Skip the step 5) for Model MR, RST, RSB and ERSB (ratchet model).

- 6) Remove five tapping screws (No.43) and dismount the clutch cover (No.10).

- 7) Remove the hexagon nut (No.47-A) , plain washer (No.46), and dodecagon hole tongued washer (No.22) in this order.

- 8) Turn the clutch (No.20) counterclockwise to disassemble.

9) Disassemble the stopper.



- **For Type SI and SIC (Stopper Armless Type)**

Remove the retaining ring C type (No.51) and the hinge pin washer (No.50) to dismount the stopper (No.23). Rotate the stopper until it no longer interferes with the torsion spring (No.80) and pull the stopper forward.

- **For Type NSIL (Noiseless Mechanism)**

Remove the retaining ring C type (No.51) and the hinge pin washer (No.50), and the magnetic plate (No.91) to dismount the stopper (No.23).

When removing the magnetic plate, make sure not to deform it. Deform of the magnetic plate may cause the malfunction of the brake.

Lastly, rotate the stopper until it no longer interfere with the torsion spring (No.80) and pull the stopper forward.

- **For other cases (Stopper Released Type)**

Remove the retaining ring C type (No.51) and the hinge pin washer (No.50), and pull the stopper (No.23) forward. Carefully pull the stopper. The steel ball in the stopper pops out.

2. Assembly of the mechanical brake unit

To assemble the brake unit, follow the procedure of disassemble in reverse.



Tighten all nuts and screws securely.

1) Wipe off the dirt or oil on the ratchet gear (No.18), ratchet metal (No.17), clutch (No.20), and the contact surface of the back plate (No.19) to the brake lining (No.21) using thinner.

2) Check that there are no scratches on the each part or no damages on the screwing part.



If any, replace the part(s) with the new one(s).

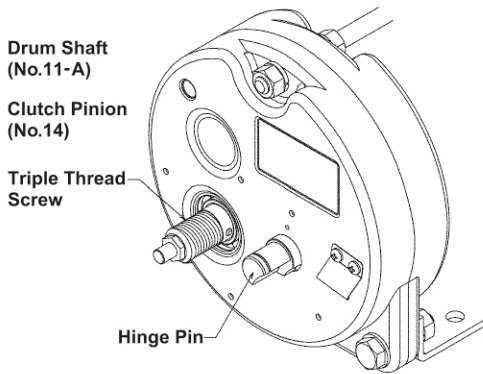

(Triple Thread Screw)

- 3) Apply grease to the triple thread screw of the clutch pinion (No.14), and the contact part of the stopper (No.23) and the hinge pin.



For winches without deceleration unit, such as Model GM-1, MR-1, MC-1, ST-1, SB-1, ESB-1, RST-1, RSB-1, ERSB-1, STC-1, SBC-1 or ESBC-1, apply grease to the triple thread screw of the drum shaft (No.11-A)



- Be sure not to apply excessive amount of grease due to the malfunction of the brake unit.

- The grease “ENEOS Corporation MULTINOC WIDE 2” is recommended.

Use this grease or an equivalent product.

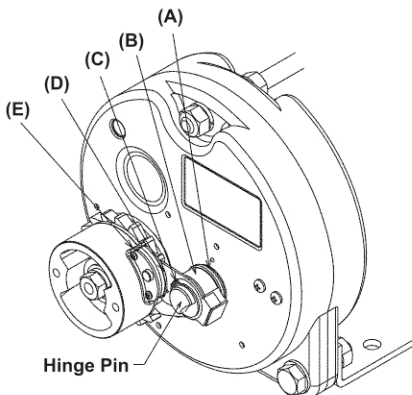

(Greasing Points for Type NSIL)

- 4) Depending on the type of the stopper, grease is applied to the movement area of steel ball or to the torsion spring (No.80).



For Type NSIL (Noiseless Mechanism), grease is also applied thinly to the moving part of the magnetic plate (No.91) and the outer circumference of the clutch (No.20) where the magnet contacts.

Greasing points on the magnetic unit for Type NSIL

- (A) – Contact part between torsion spring and hinge pin
- (B) – Contact part between hinge pin and stopper
- (C) – Contact part among the magnetic unit, hinge pin washer and retaining ring C type
- (D) – Connecting part between linkage screw and linkage plate
- (E) – Contact part between magnet and clutch
(Thinly applied on the outer circumference)

Following steps describe the procedures to assemble the clutch

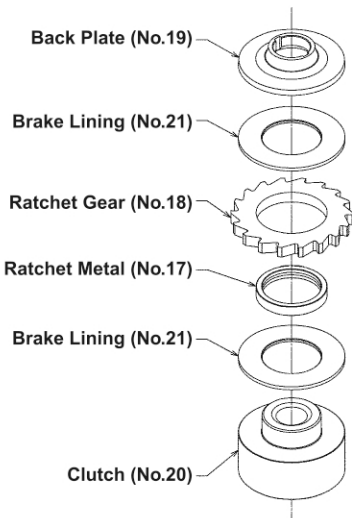

(Clutch Set)

5) Assemble the following order; the clutch (No.20), the brake lining (No.21), the ratchet metal (No.17), the ratchet gear (No.18), and the brake lining (No.21).



The min. thickness of the brake lining is 2.45mm (0.0965 inch).



Apply grease thinly to the inner groove of the ratchet metal (No.17).

6) Set the back plate (No.19) to the winch side.

7) Tighten the clutch (No.20) set at the step 5) to the triple thread screw while rotating the clutch clockwise.



DANGER Make sure that the direction of the ratchet gear (No.18) teeth mesh with the stopper. If wrongly installed, ratchet gear does not mesh with the stopper result in malfunction of the brake unit.

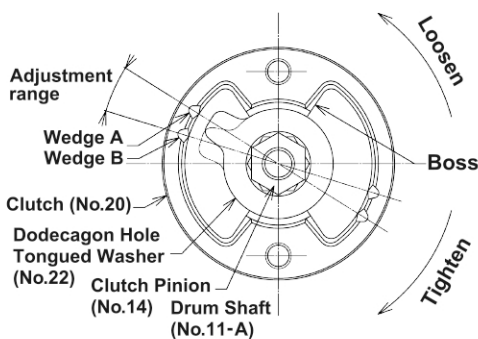

(The angle of the dodecagon hole tongued washer)

8) With the clutch (No.20) fully tightened, adjust the dodecagon hole tongued washer (No.22) so that it is close to wedge A between the two wedge marks as shown on the left.



When the angle is greater, the stop time of the brake unit may get longer or the brake unit has slippage.

9) Check that the stopper operates smoothly by rotating the clutch in the lifting direction (clockwise).

10) Cover the clutch cover (No.10).

11) Check that the brake unit operates properly.



Refer to “4.1.2 Checking the Brake Operation”.

5.2 Maintenance

The troubleshooting and its measures for the MAXPULL winch are described in the table below.

 WARNING
<ul style="list-style-type: none"> • All loads must be lowered before any maintenance work and make sure that there is no load on the wire rope and the winch. • Only qualified personnel with designated knowledge can perform the maintenance work. • Post a tag or placard stating “UNDER MAINTENANCE WORK” to prevent the winch being operated accidentally by the other personnel during the maintenance work. • If there is any defect on the winch, always replace or repair before winch operation. • When replacing any parts, always use the genuine parts.

5.2.1 Troubleshooting and its measures

Problem	Checking of the Cause	Measure
Malfunction of the brake unit	Is the wire rope being wound in reverse?	Check the wire rope winding direction. Make the wire rope wind when the handle is turned clockwise.
	Is the wire rope loosened?	The brake unit does not work without load. Apply a load to the winch.
	Check if there are any dust, obstacles or water on the mechanical brake unit by removing the clutch cover.	If any, clean the brake unit referring the disassembly and inspection of the mechanical brake unit.
	Maladjustment of mechanical brake unit	Adjustment of the mechanical brake unit referring the disassembly and inspection of the mechanical brake unit.
	Load is too small.	The brake unit may not operate properly when the load is insufficient. Use a winch which is appropriate for the load.

Problem	Checking of the Cause	Measure
Malfunction of the brake unit	Brake lining abrasion	Replace to the new brake lining referring to the disassembly and inspection of the mechanical brake unit.
	Damage on the mechanical brake unit.	Replace to the new brake unit referring to the disassembly and inspection of the mechanical brake unit.
	Is the minimum temperature is -10°C (14°F) or lower at the installation site or site of usage?	Contact to MAXPULL.
Lowering cannot be performed.	Engagement of the mechanical brake unit	The mechanical brake unit is tighten too much. Strongly turn the handle in lowering direction.
The handle does not turn.	Damage on the gear or the other parts by excessive load.	Replace the damaged parts.
Abnormal sound during operation	Abrasion of the gear or the bearing	Replace the abraded parts.
Suddenly, the handle force becomes heavy.	Excessive winding the wire rope	Do not wind more than the capacity. It may cause the brake down of the winch.
	The load may be caught on something.	Stop the operation and remove any obstacles before restart the operation.
	Check if the wire rope is twisted or kinked.	Replace the wire rope.
Suddenly, the handle force becomes light.	The load may be caught on something.	Stop the operation and remove any obstacles before restart the operation.



The performance of the mechanical brake unit drops after the engagement.

Disassemble and inspect the mechanical brake unit.

APPENDIX

Appendix 1. MAXPULL Winch Inspection Sheet App-1

Appendix 2. Parts List for Each Model App-2

Appendix 1. MAXPULL Winch Inspection Sheet

Inspector _____

Inspection Date year month day _____

Model _____

Serial Number _____

Inspection Period		Contents of Inspection	Judgement
Daily	Periodically		
<input type="radio"/>	<input type="radio"/>	The name plate and warning labels are affixed in the correct locations, and are clearly legible.	Pass / Fail
<input type="radio"/>	<input type="radio"/>	The mounting bolts of the winch are not loosened.	Pass / Fail
<input type="radio"/>	<input type="radio"/>	There is no defect on the installation base of the winch.	Pass / Fail
<input type="radio"/>	<input type="radio"/>	There is no damage, missing parts, or defect on the winch.	Pass / Fail
<input type="radio"/>	<input type="radio"/>	All bolts, nuts and screws are tightened securely.	Pass / Fail
<input type="radio"/>	<input type="radio"/>	The handle operates properly.	Pass / Fail
<input type="radio"/>	<input type="radio"/>	Checking of brake operation.	Pass / Fail
<input type="radio"/>	<input type="radio"/>	The wire rope winding direction is correct.	Pass / Fail
<input type="radio"/>	<input type="radio"/>	There is no kink on the wire rope.	Pass / Fail
<input type="radio"/>	<input type="radio"/>	There is no frayed the element wire of the wire rope.	Pass / Fail
<input type="radio"/>	<input type="radio"/>	The wire rope is lubricated properly.	Pass / Fail
<input type="radio"/>	<input type="radio"/>	The wire rope diameter has not fallen by 7% or more of its nominal diameter.	Pass / Fail
<input type="radio"/>	<input type="radio"/>	There is no defect at the end of the wire rope and its anchoring section.	Pass / Fail
<input type="radio"/>	<input type="radio"/>	The wire rope is not deformed.	Pass / Fail
<input type="radio"/>	<input type="radio"/>	The wire rope is not corroded.	Pass / Fail
<input type="radio"/>	<input type="radio"/>	The wire rope is wound to the drum properly.	Pass / Fail
<input type="radio"/>	<input type="radio"/>	The fleet angle is 2 degrees or less.	Pass / Fail
<input type="radio"/>	<input type="radio"/>	The sufficient amount of extra maintenance winding is kept. (Model GM,MR,ST,SB,ESB,RST,RSB and ERSB)	Pass / Fail
<input type="radio"/>	<input type="radio"/>	The wire rope is wound 5 or 7 times to the drum. (Model MC,STC,SBC and ESBC)	Pass / Fail
<input type="radio"/>	<input type="radio"/>	The sufficient hauling tension is on the wire rope. (Model MC,STC,SBC and ESBC)	Pass / Fail
Refer to "5.1.2 Disassembly and inspection of the mechanical brake unit" for the following inspection items.			
<input type="checkbox"/>	<input type="radio"/>	No damage on the brake lining and the thickness is 2.45mm (0.0965inch) or more.	Pass / Fail
<input type="checkbox"/>	<input type="radio"/>	There is no damage, abrasion or deform on the stopper.	Pass / Fail
<input type="checkbox"/>	<input type="radio"/>	There is no damage, abrasion or deform on the ratchet gear.	Pass / Fail
<input type="checkbox"/>	<input type="radio"/>	There is no damage, abrasion or deform on the ratchet metal.	Pass / Fail
<input type="checkbox"/>	<input type="radio"/>	There is no damage, abrasion or deform on the hinge pin.	Pass / Fail
<input type="checkbox"/>	<input type="radio"/>	There is no damage, abrasion or deform on the triple thread screw.	Pass / Fail
<input type="checkbox"/>	<input type="radio"/>	There is no damage, abrasion or deform on the clutch.	Pass / Fail
<input type="checkbox"/>	<input type="radio"/>	The angle of the dodecagon hole tongued washer is 10 to 15 degrees.	Pass / Fail
<input type="checkbox"/>	<input type="radio"/>	There is no damage, abrasion or deform on the ratchet handle and switch pin. (Model MR,RSB,RST and ERSB)	Pass / Fail
<input type="checkbox"/>	<input type="radio"/>	There is no damage, abrasion or deform on the ratchet wheel and the axis. (Model MR) (Model MR,RSB,RST and ERSB)	Pass / Fail
<input type="checkbox"/>	<input type="radio"/>	There is no damage, abrasion or deform on the torsion spring and operate properly. (Type SI, SIC and NSIL)	Pass / Fail
<input type="checkbox"/>	<input type="radio"/>	There is no damage, abrasion or deform on the magnetic plate and operate properly. (Type NSIL)	Pass / Fail

* If any defects are found during inspection, correct them before the operation.
 * When repairs are required, clearly states that the winch is "OUT OF ORDER" to prevent the winch being used accidentally.

Remarks _____

2. Parts List for GM-1, MR-1, MC-1, ST-1, SB-1, ESB-1, RST-1, RSB-1, ERSB-1, STC-1, SBC-1 and ESBC-1

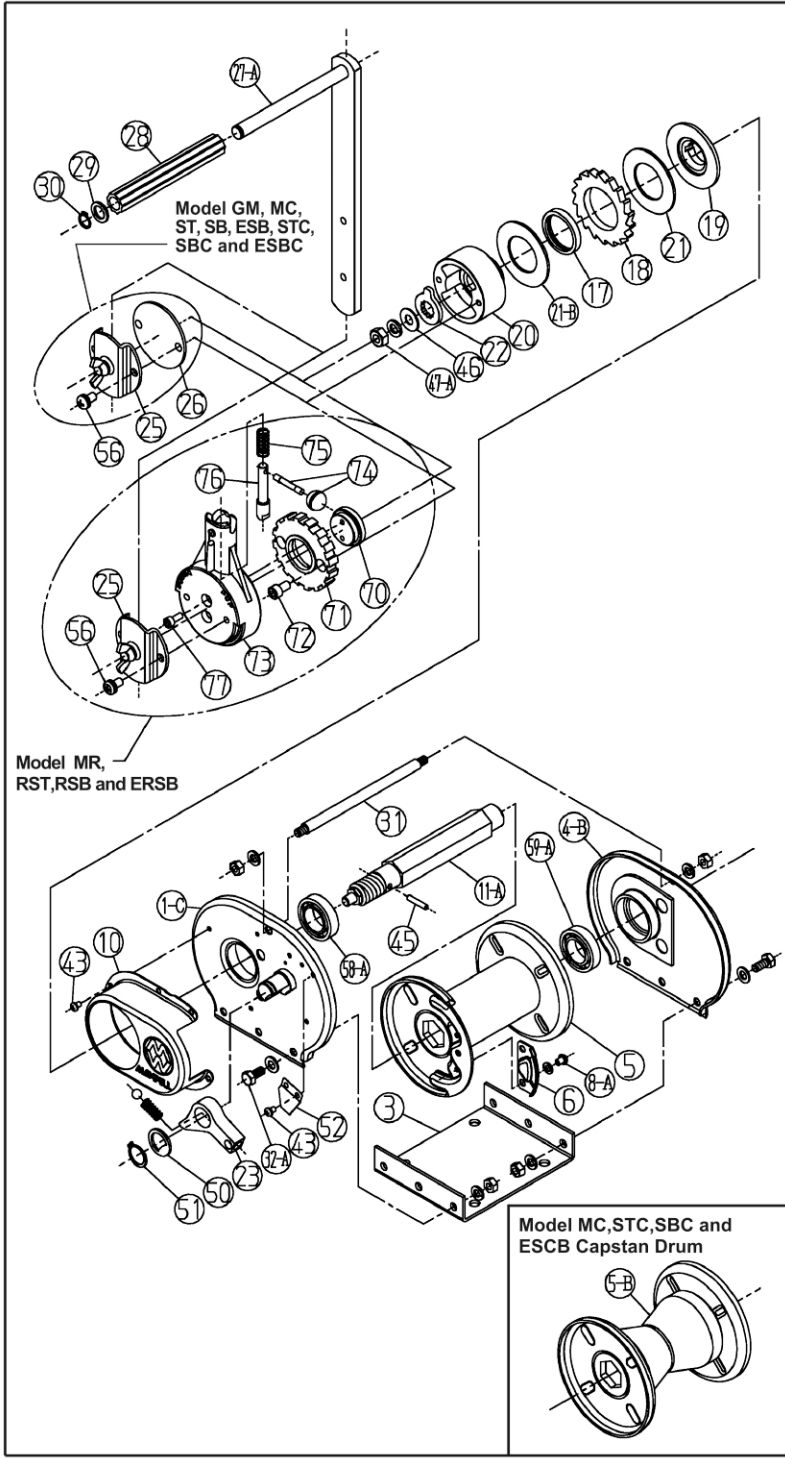

Part No.	Part Name	Qty	Remarks
1-C	Side Frame A	1	
3	Bed Plate	1	
4-B	Side Frame B	1	
5	Drum	1	*1
6	Wire Anchoring Plate	1	
8-A	Hexagon Socket Button Head Cap Screw M6×10	2	*2
10	Clutch Cover	1	
11-A	Drum Shaft	1	
17	Ratchet Metal	1	
18	Ratchet Gear	1	
19	Back Plate	1	
20	Clutch	1	
21	Brake Lining	2	
22	Dodecagon Hole Tongued Washer	1	
23	Stopper	1	Set *3
25	Handle Holder	1	
26	Clutch Shield Plate	1	*4
27-A	Handle Arm	1	
28	Handle Grip	1	
29	Handle Washer	1	
30	Retaining Ring C Type	S-14	1
31	Stay Bolt	M8	1 *5
32-A	Hexagon Head Bolt	M8×18	6 *6
43	Tapping Screw	M5×8	7
45	Parallel Pin		1
46	Washer		1
47-A	Hexagon Nut	M10	1 *2
50	Hinge Pin Washer		1
51	Retaining Ring C Type	S-22	1
52	Safety Leaf Spring		1
56	Phillips Pan Head Screw	M8×15	2
58-A	Bearing	6005ZZ	1
59-A	Bearing	6005ZZ	1
70	Axis		1 Model MR
71	Ratchet Wheel		1 Model MR
72	Hexagon Socket Head Cap Screw	M8×15	2 Model MR
73	Ratchet Handle		1 Model MR
74	Switch Lever		1 Set Model MR
75	Coil Spring		1 Model MR
76	Switch Pin		1 Model MR
77	Hexagon Socket Head Cap Screw	M6×15	2 Model MR
5-B	Capstan Drum	1	Model MC

- * 1 No.5-B for Model MC, STC, SBC and ESBC
- * 2 with Helical Spring Lock Washer
- * 3 with Ball and Spring ASSY
- * 4 Not attached on Model MR, RST, RSB and ERSB
- * 5 with 2 Nuts and 2 Helical Spring Lock Washers
- * 6 with Helical Spring Lock Washer, Plain Washer and Nut
- * 7 M8×16 for Model ST, SB, ESB, RST, RSB, ERSB, STC, SBC and ESBC
- * 8 6005ZZ Stainless Steel Bearing for Model ST, SB, ESB, RST, RSB, ERSB, STC, SBC and ESBC

3. Parts List for GM-3, MR-3, MC-3, ST-3, SB-3, ESB-3, RST-3, RSB-3, ERSB-3, STC-3, SBC-3 and ESBC-3

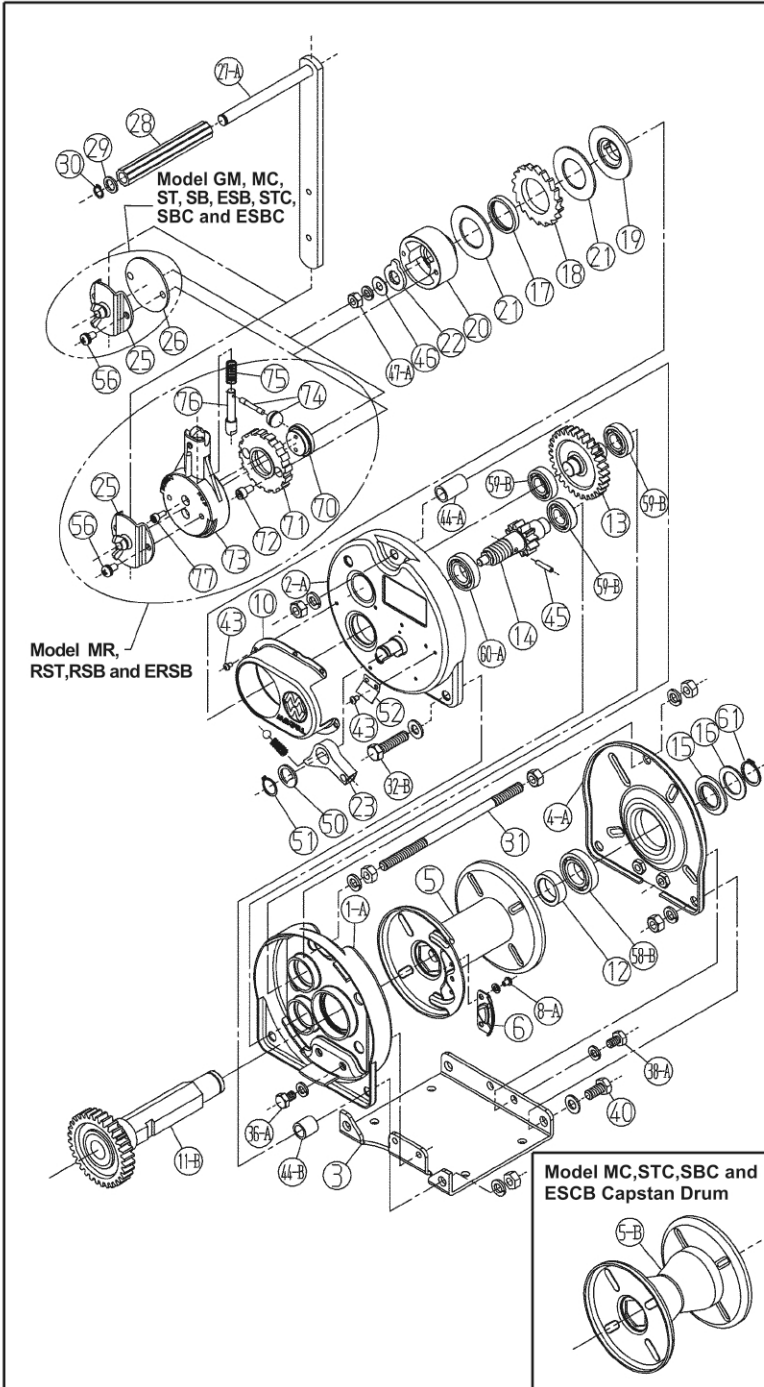

Part No.	Part Name	Qty	Remarks
1-A	Gear Case	1	
2-A	Gear Case Cover	1	
3	Bed Plate	1	
4-A	Side Frame	1	
5	Drum	1	*1
6	Wire Anchoring Plate	1	
8-A	Hexagon Socket Button Head Cap Screw M6×10	2	*2
10	Clutch Cover	1	
11-B	Drum Shaft Main Gear	1Set	*3
12	Shaft Distance Piece	1	
13	Spur Gear Pinion	1Set	
14	Clutch Pinion	1	
15	Shaft Washer A	1	
16	Shaft Washer B	1	
17	Ratchet Metal	1	
18	Ratchet Gear	1	
19	Back Plate	1	
20	Clutch	1	
21	Brake Lining	2	
22	Dodecagon Hole Tongued Washer	1	
23	Stopper	1Set	*4
25	Handle Holder	1	
26	Clutch Shield Plate	1	*5
27-A	Handle Arm	1	
28	Handle Grip	1	
29	Handle Washer	1	
30	Retaining Ring C Type S-14	1	
31	Stay Bolt M12	1	*6
32-B	Hexagon Head Bolt M12×50	2	*7
36-A	Hexagon Head Bolt M10×16	2	*2
38-A	Hexagon Head Bolt M10×16	2	*2
40	Hexagon Head Bolt M12×25	2	*7
43	Tapping Screw M5×8	7	
44-A	Spacer	1	
44-B	Spacer	2	
45	Parallel Pin	1	
46	Washer	1	
47-A	Hexagon Nut M10	1	*2
50	Hinge Pin Washer	1	
51	Retaining Ring C Type S-22	1	
52	Safety Leaf Spring	1	
56	Phillips Pan Head Screw M8×15	2	*8
58-B	Bearing 6006ZZ	1	*9
59-B	Bearing 6004ZZ	3	*10
60-A	Bearing 6005ZZ	1	*11
61	Retaining Ring C Type S-30	1	
70	Axis	1	Model MR
71	Ratchet Wheel	1	Model MR
72	Hexagon Socket Head Cap Screw M8×15	2	Model MR
73	Ratchet Handle	1	Model MR
74	Switch Lever	1Set	Model MR
75	Coil Spring	1	Model MR
76	Switch Pin	1	Model MR
77	Hexagon Socket Head Cap Screw M6×15	2	Model MR
5-B	Capstan Drum	1	Model MC

- * 1 No.5-B for Model MC, STC, SBC and ESBC
- * 2 with Helical Spring Lock Washer
- * 3 with Bearing ASSY
- * 4 with Ball and Spring ASSY
- * 5 Not attached on Model MR, RST, RSB and ERSB
- * 6 with 4 Nuts and 3 Helical Spring Lock Washers
- * 7 with Helical Spring Lock Washer, Plain Washer and Nut
- * 8 M8×16 for Model ST, SB, ESB, RST, RSB, ERSB, STC, SBC and ESBC
- * 9 6006ZZ Stainless Steel Bearing for Model ST, SB, ESB, RST, RSB, ERSB, STC, SBC and ESBC
- * 10 6004ZZ Stainless Steel Bearing for Model ST, SB, ESB, RST, RSB, ERSB, STC, SBC and ESBC
- * 11 6005ZZ Stainless Steel Bearing for Model ST, SB, ESB, RST, RSB, ERSB, STC, SBC and ESBC

4. Parts List for GM-5 & 10, MR-5 & 10, MC-5 & 10, ST-5 & 10, SB-5 & 10, ESB-5 & 10, RST-5 & 10, RSB-5 & 10, ERSB-5 & 10, STC-5 & 10, SBC-5 & 10 and ESBC-5 & 10

Part No.	Part Name	Qty	Remarks
1-A	Gear Case	1	
2-A	Gear Case Cover	1	
3	Bed Plate	1	
4-A	Side Frame	1	
5	Drum	1	*1
6	Wire Anchoring Plate	1	
8-B	Hexagon Socket Button Head Cap Screw M6×10	4	*2
10	Clutch Cover	1	
11-B	Drum Shaft Main Gear	1	*3
12	Shaft Distance Piece	1	
13	Spur Gear Pinion	1	Set
14	Clutch Pinion	1	
15	Shaft Washer A	1	
16	Shaft Washer B	1	
17	Ratchet Metal	1	
18	Ratchet Gear	1	
19	Back Plate	1	
20	Clutch	1	
21	Brake Lining	2	
22	Dodecagon Hole Tongued Washer	1	
23	Stopper	1	Set *4
25	Handle Holder	1	
26	Clutch Shield Plate	1	*5
27-A	Handle Arm	1	*8
28	Handle Grip	1	
29	Handle Washer	1	
30	Retaining Ring C Type S-14	1	
31	Slay Bolt M12	1	*6
32-B	Hexagon Head Bolt M12×50	2	*7
36-A	Hexagon Head Bolt M10×16	2	*2
38-A	Hexagon Head Bolt M10×16	2	*2
40	Hexagon Head Bolt M12×25	2	*7
43	Tapping Screw M5×8	7	
44-A	Spacer	1	
44-B	Spacer	2	
45	Parallel Pin	1	
46	Washer	1	
47-A	Hexagon Nut M10	1	*2
50	Hinge Pin Washer	1	
51	Retaining Ring C Type S-22	1	
52	Safety Leaf Spring	1	
56	Phillips Pan Head Screw M8×15	2	*9
58-B	Bearing 6006ZZ	1	*10
59-B	Bearing 6004ZZ	3	*11
60-A	Bearing 6005ZZ	1	*12
61	Retaining Ring C Type S-30	1	
70	Axis	1	Model MR
71	Ratchet Wheel	1	Model MR
72	Hexagon Socket Head Cap Screw M8×15	2	Model MR
73	Ratchet Handle	1	Model MR
74	Switch Lever	1	Set Model MR
75	Coil Spring	1	Model MR
76	Switch Pin	1	Model MR
77	Hexagon Socket Head Cap Screw M6×15	2	Model MR
5-B	Capstan Drum	1	Model MC

- * 1 No.5-B for Model MC, STC, SBC and ESBC
- * 2 with Helical Spring Lock Washer
- * 3 with Bearing ASSY
- * 4 with Ball and Spring ASSY
- * 5 Not attached on Model MR, RST, RSB and ERSB
- * 6 with 4 Nuts and 3 Helical Spring Lock Washers
- * 7 with Helical Spring Lock Washer, Plain Washer and Nut
- * 8 for GM-5, MR-5, MC-5, ST-5, ST-10, SB-5, SB-10, ESB-5, ESB-10, RST-5, RST-10, RSB-5, RSB-10, ERSB-5, ERSB-10, STC-5, STC-10, SBC-5, SBC-10, ESBC-5 and ESBC-10 have no hole
- * 9 M8×16 for Model ST, SB, ESB, RST, RSB, ERSB, STC, SBC and ESBC
- * 10 6006ZZ Stainless Steel Bearing for Model ST, SB, ESB, RST, RSB, ERSB, STC, SBC and ESBC
- * 11 6004ZZ Stainless Steel Bearing for Model ST, SB, ESB, RST, RSB, ERSB, STC, SBC and ESBC
- * 12 6005ZZ Stainless Steel Bearing for Model ST, SB, ESB, RST, RSB, ERSB, STC, SBC and ESBC

5. Parts List for GM-20, MR-20 and MC-20

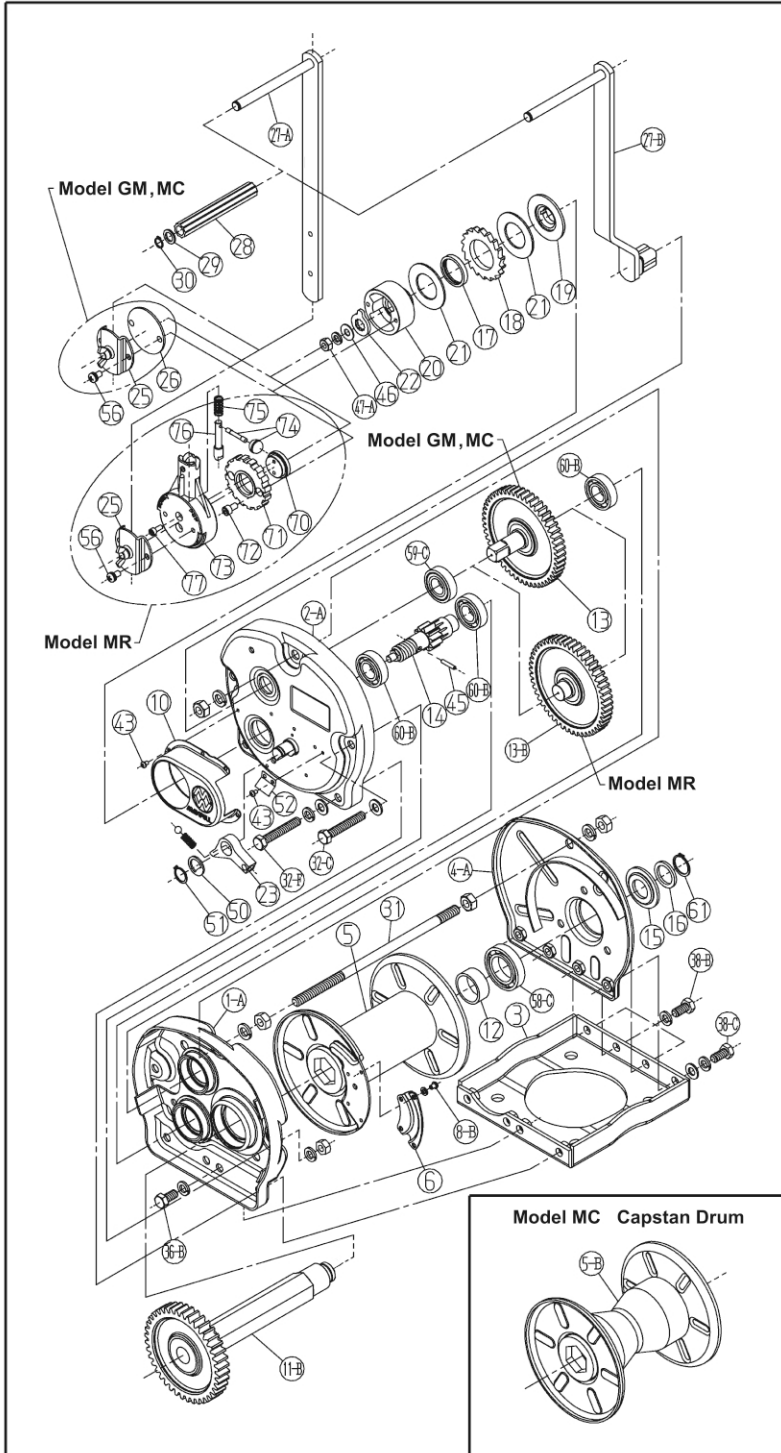

Part No.	Part Name	Qty	Remarks
1-A	Gear Case	1	
2-A	Gear Case Cover	1	
3	Bed Plate	1	
4-A	Side Frame	1	
5	Drum	1	*1
6	Wire Anchoring Plate	1	
8-B	Hexagon Socket Button Head Cap Screw M6×10	4	*2
10	Clutch Cover	1	
11-B	Drum Shaft Main Gear	1	Set *3
12	Shaft Distance Piece	1	
13	Spur Gear Pinion	1	Set *4
14	Clutch Pinion	1	
15	Shaft Washer A	1	
16	Shaft Washer B	1	
17	Ratchet Metal	1	
18	Ratchet Gear	1	
19	Back Plate	1	
20	Clutch	1	
21	Brake Lining	2	
22	Dodecagon Hole Tongued Washer	1	
23	Stopper	1	Set *5
25	Handle Holder	1	
26	Clutch Shield Plate	1	*6
27-A	Handle Arm	1	
27-B	Box handle Arm	1	*6
28	Handle Grip	2	
29	Handle Washer	2	
30	Retaining Ring C Type	S-14	2
31	Stay Bolt	M14	1 *7
32-C	Hexagon Head Bolt	M12×75	2 *8
32-F	Hexagon Head Bolt	M12×80	2 *9
36-B	Hexagon Head Bolt	M12×25	2 *2
38-B	Hexagon Head Bolt	M12×25	3 *2
38-C	Hexagon Head Bolt	M12×25	1 *9
43	Tapping Screw	M5×8	7
45	Parallel Pin		1
46	Washer		1
47-A	Hexagon Nut	M10	1 *2
50	Hinge Pin Washer		1
51	Retaining Ring C Type	S-22	1
52	Safety Leaf Spring		1
56	Phillips Pan Head Screw	M8×15	2
58-C	Bearing	6008Z	1
59-C	Bearing	6205Z	1
60-B	Bearing	6205	3
61	Retaining Ring C Type	S-30	1
70	Axis		1 Model MR
71	Ratchet Wheel		1 Model MR
72	Hexagon Socket Head Cap Screw	M8×15	2 Model MR
73	Ratchet Handle		1 Model MR
74	Switch Lever		1 Set Model MR
75	Coil Spring		1 Model MR
76	Switch Pin		1 Model MR
77	Hexagon Socket Head Cap Screw	M6×15	2 Model MR
13-B	Spur Gear Pinion		1 Set Model MR
5-B	Capstan Drum		1 Model MC

- * 1 No.5-B for Model MC
- * 2 with Helical Spring Lock Washer
- * 3 with Bearing ASSY
- * 4 No.13-B for Model MR
- * 5 with Ball and Spring ASSY
- * 6 Not attached on Model MR
- * 7 with 4 Nuts and 3 Helical Spring Lock Washers
- * 8 with Helical Spring Lock Washer, Plain Washer and Nut
- * 9 with Helical Spring Lock Washer and Plain Washer

6. Parts List for GM-30 and MR-30

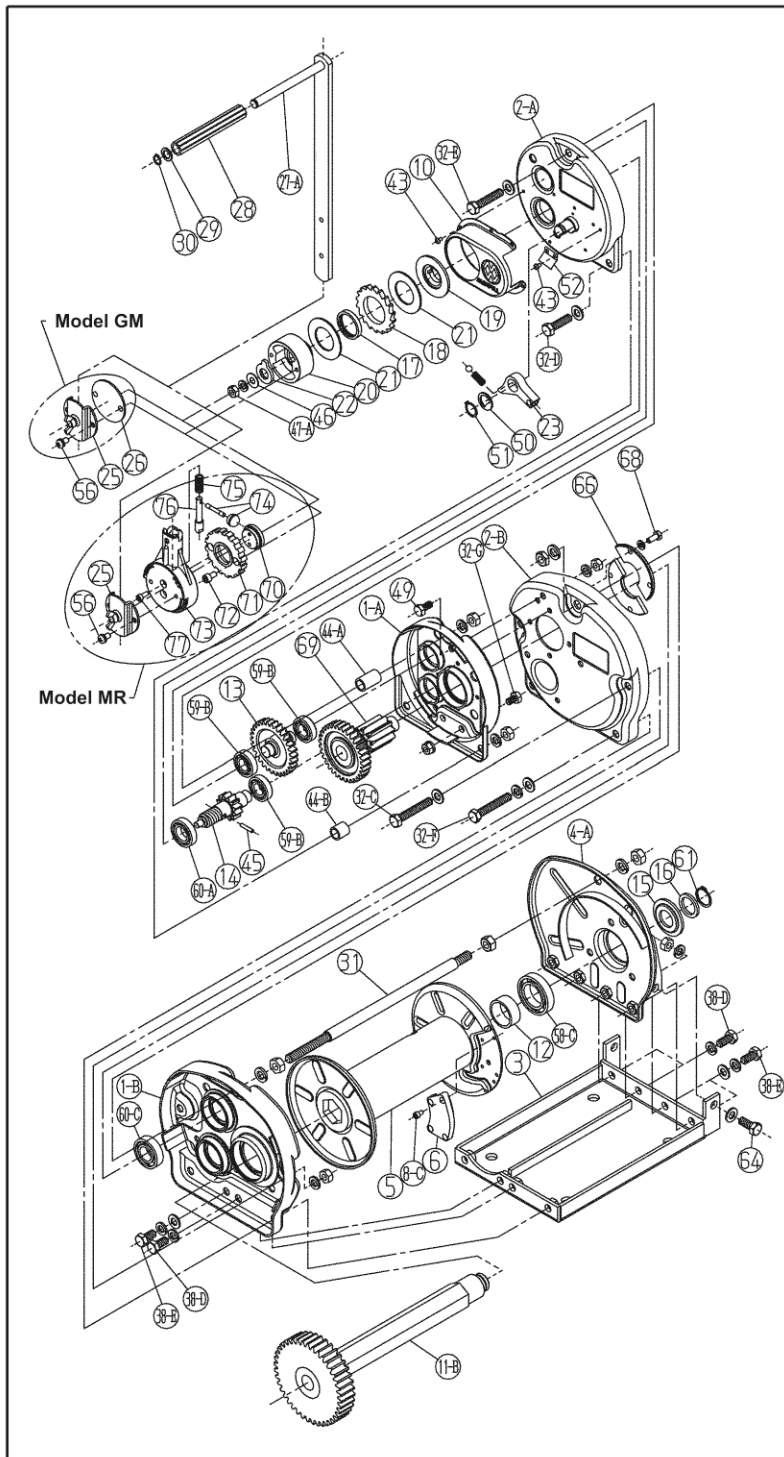

Part No.	Part Name	Qty	Remarks
1-A	Gear Case Small	1	
1-B	Gear Case Large	1	
2-A	Gear Case Cover Small	1	
2-B	Gear Case Cover Large	1	
3	Bed Plate	1	
4-A	Side Frame	1	
5	Drum	1	
6	Wire Anchoring Plate	1	
8-C	Hexagon Socket Head Cap Screw	M6×10	4
10	Clutch Cover	1	
11-B	Drum Shaft Main Gear	1Set	*1
12	Shaft Distance Piece	1	
13	Spur Gear Pinion	1Set	
14	Clutch Pinion	1	
15	Shaft Washer A	1	
16	Shaft Washer B	1	
17	Ratchet Metal	1	
18	Ratchet Gear	1	
19	Back Plate	1	
20	Clutch	1	
21	Brake Lining	2	
22	Dodecagon Hole Tongued Washer	1	
23	Stopper	1Set	*2
25	Handle Holder	1	
26	Clutch Shield Plate	1	*3
27-A	Handle Arm	1	
28	Handle Grip	1	
29	Handle Washer	1	
30	Retaining Ring C Type	S-14	1
31	Stay Bolt	M14	1 *4
32-C	Hexagon Head Bolt	M12×75	2 *5
32-D	Hexagon Head Bolt	M12×45	2 *5
32-E	Hexagon Head Bolt	M12×60	1 *5
32-F	Hexagon Head Bolt	M12×80	2 *6
32-G	Hexagon Head Bolt	M10×16	2 *7
38-D	Hexagon Head Bolt	M12×25	3 *8
38-E	Hexagon Head Bolt	M12×25	3 *6
43	Tapping Screw	M5×8	7
44-A	Spacer		1
44-B	Spacer		2
45	Parallel Pin		1
46	Washer		1
47-A	Hexagon Nut	M10	1 *8
49	Hexagon Head Bolt	M10×22	3 *7
50	Hinge Pin Washer		1
51	Retaining Ring C Type	S-22	1
52	Safety Leaf Spring		1
56	Phillips Pan Head Screw	M8×15	2
58-C	Bearing	6008Z	1
59-B	Bearing	6004	3
60-A	Bearing	6005	1
60-C	Bearing	6205	1
61	Retaining Ring C Type	S-30	1
64	Hexagon Head Bolt	M12×30	2 *5
66	Division Disc		1Set *9
68	Hexagon Head Bolt	M8×20	4 *8
69	Main Gear Pinion		1Set *10
70	Axis		1 Model MR
71	Ratchet Wheel		1 Model MR
72	Hexagon Socket Head Cap Screw	M8×15	2 Model MR
73	Ratchet Handle		1 Model MR
74	Switch Lever		1Set Model MR
75	Coil Spring		1 Model MR
76	Switch Pin		1 Model MR
77	Hexagon Socket Head Cap Screw	M6×15	2 Model MR

- * 1 with Bearing ASSY
- * 2 with Ball and Spring ASSY
- * 3 Not attached on Model MR
- * 4 with 4 Nuts and 3 Helical Spring Lock Washers
- * 5 with Helical Spring Lock Washer, Plain Washer and Nut
- * 6 with Helical Spring Lock Washer and Plain Washer
- * 7 with Nut and Helical Spring Lock Washer
- * 8 with Helical Spring Lock Washer

- * 9 4 Pieces Set
- * 10 with Bearing

Safety Information

Read this manual thoroughly before installing and using this product,
operate the winch correctly.

Comply with relevant laws and regulations.

Quality Certificate 



MAXPULL MACHINERY & ENGINEERING CO.,LTD.

マックスプル工業株式会社

1296-22, Nakaya, Nishifukai, Nagareyama-shi

Chiba 270-0107 JAPAN

TEL: +81-4-7186-6797 FAX: +81-4-7186-6798

Web Site : <http://www.maxpull.co.jp>

E-mail : maxpull@maxpull.co.jp